

TECHNICAL GUIDE; CHARACTERISTICS

SI/50Hz

SI

SUPDOCTGQDATA7-0.ORD 12.1.2018

- - - -

083544 13.3.2018

SWF Krantechnik GmbH

Postbox 310410
68264 Mannheim
Germany

Boehringerstraße 4
68307 Mannheim
Germany

tel +49(0)621 789-900
fax +49(0)621 789 90-100
Info@swfkrantechnik.com
www.swfkrantechnik.com

Table of contents

1 HOIST STANDARD FEATURES.....3

1.1 NB Standard features.....3

1.2 NC Standard features.....4

1.3 ND Standard features.....5

1.4 NE Standard features.....6

1.5 NF Standard features7

1.6 SWF code example (SWF: Nova, Factory: Q).....8

2 TECHNICAL CHARACTERISTICS.....10

3 HOISTING MOTORS25

3.1 Hoisting motor data, two speed pole change motors, 50 Hz25

3.2 Hoisting motor currents, two speed pole change motors, 50 Hz27

3.3 Hoisting motor data, two speed pole change motors, 60 Hz28

3.4 Hoisting motor currents, two speed pole change motors, 60 Hz30

3.5 Hoisting motor data, frequency converter motors, 50 Hz and 60 Hz31

3.6 Hoisting motor currents, frequency converter motors, 50 Hz and 60 Hz31

3.7 Hoisting motor data, frequency converter motors, 100 Hz32

3.8 Hoisting motor data, frequency converter motors, 120 Hz33

3.9 Hoisting motor data, frequency converter motors, 125 Hz34

3.10 Hoisting motor currents, frequency converter motors, 100 Hz, 120 Hz and 125 Hz35

4 TRAVELING MOTORS36

4.1 Frequency converter traveling motors 3000 rpm (100 Hz), 3600 rpm (120 Hz) and 4800 rpm (80 Hz)36

4.2 Two-speed traveling motors 3000/750 rpm (50 Hz) and 3600/900 rpm (60 Hz)38

5 TROLLEY SPEED TABLES40

5.1 Trolley traveling speed range, Frequency converter control40

5.2 Trolley traveling speeds, Contactor control43

6 SURFACE TREATMENT44

6.1 Standard painting system44

6.2 Color codes.....44

7 WIRE ROPE DATA45

8 MATERIALS.....46

1 HOIST STANDARD FEATURES

1.1 NB Standard features

Hoisting	<input type="checkbox"/> Strain gauge as overload protector <input type="checkbox"/> 4-step hoisting limit switch <input type="checkbox"/> ISO M4, 180 starts/h, 30% ED <input type="checkbox"/> ISO M5, 240 starts/h, 40% ED <input type="checkbox"/> ISO M6, 300 starts/h, 50% ED
Hoist motor	<input type="checkbox"/> Two-speed pole-change hoisting motor, 6:1 speed ratio <input type="checkbox"/> 300 starts/h, 60 % ED <input type="checkbox"/> H class insulation <input type="checkbox"/> IP55 protection <input type="checkbox"/> Klixon type bimetal switch for thermal protection
Hook	<input type="checkbox"/> Capacity and duty rating EN13001-3-5, ISO 17440 (ASME B30.10) <input type="checkbox"/> Hook forging strength class V (DIN15400) <input type="checkbox"/> Reeving 02: Hook forging type RSN1 (DIN15401) <input type="checkbox"/> Reeving 04: Hook forging type HBC with hand grip, size 1.6 (DIN15401) <input type="checkbox"/> Safety latch
Rope reeving	<input type="checkbox"/> EN-GJS-700-3 cast iron rope guide incl. pressure roll for slack rope protection. Machinery hoists: pressure bar along the drum to hold the rope <input type="checkbox"/> EN-GJS-500-7 rope sheaves <input type="checkbox"/> Rope sheave / rope diameter ratio according to ISO M6 duty class as minimum
Travelling	<input type="checkbox"/> Low headroom trolley flange width range 80–410 mm <input type="checkbox"/> Normal headroom trolley flange width ranges - 02 reeving: 80–450 mm - 04 reeving: 80–450 mm <input type="checkbox"/> Medium double girder trolley rail gauges 1200, 1400, 1700, 2000 mm <input type="checkbox"/> High mounted double girder trolley rail gauge 900, 1200, 1400, 1700, 2000 mm <input type="checkbox"/> One travel motor in trolley. In N-trolley the amount depends on reeving system <input type="checkbox"/> EN-GJS-500-7 cast iron flanged rail wheels, 2 driven by travelling machinery. The wheel groove width is 65 mm as standard for double girder trolley <input type="checkbox"/> 4 pcs rubber buffers <input type="checkbox"/> Jump-off protection in single girder trolleys (N, L) <input type="checkbox"/> Axle failure protection in both double and single girder trolleys
Travel machinery	<input type="checkbox"/> Frequency converter motor with compact brake, converter in hoist panel <input type="checkbox"/> Two adjustable speeds with ramp functions min. 5 m/min, max. 20 m/min (MS2-control) <input type="checkbox"/> S3 duty, 40 % ED
Electrical outfit	<input type="checkbox"/> Standard 3-phase voltages 50Hz: 220V*, 230V*, 240V*, 380V, 400V, 415V, 500V*, 525V* <input type="checkbox"/> Standard 3-phase voltages 60Hz: 220V*, 230V*, 240V*, 440V, 460V, 480V, 575V*, 600V* <input type="checkbox"/> (*additional price and delivery time) <input type="checkbox"/> Standard control voltages 48V / 50Hz, 115V / 50Hz or 60Hz, 230V / 50Hz or 60Hz <input type="checkbox"/> Assembly according to IEC standards <input type="checkbox"/> IP 55 / NEMA 3R steel control panel <input type="checkbox"/> Electrics for single hoist use in crane application (main contactor nor control voltage transformer not included) <input type="checkbox"/> Plug in connectors for power supply and control cables
Environment	<input type="checkbox"/> Standard operating temperature range is +5°C...+40°C. Optional features can extend the temperature range to -20°C...+55°C. Special designs available on request for colder and hotter environments.
Surface treatment	<input type="checkbox"/> See Section 7 and 9 for details
Marking	<input type="checkbox"/> Hoist type plate incl. CE mark <input type="checkbox"/> Rope code sticker <input type="checkbox"/> Hoist stickers: brand name and type designation <input type="checkbox"/> Hook stickers: brand name and load
Documents	<input type="checkbox"/> 1 pcs Hoist Owner's Manual <input type="checkbox"/> Hoist test certificate <input type="checkbox"/> Wire rope certificate <input type="checkbox"/> Hook certificate
Delivery	<input type="checkbox"/> Wooden crate packing. Size according to the trolley <input type="checkbox"/> Anticorrosion plastics around the hoist

1.2 NC Standard features

Hoisting	<input type="checkbox"/> Strain gauge as overload protector <input type="checkbox"/> 4-step hoisting limit switch <input type="checkbox"/> ISO M4, 180 starts/h, 30% ED <input type="checkbox"/> ISO M5, 240 starts/h, 40% ED <input type="checkbox"/> ISO M6, 300 starts/h, 50% ED
Hoist motor	<input type="checkbox"/> Two-speed pole-change hoisting motor, 6:1 speed ratio <input type="checkbox"/> 300 starts/h, 60 % ED <input type="checkbox"/> H class insulation <input type="checkbox"/> IP55 protection <input type="checkbox"/> Klixon type bimetal switches for thermal protection
Hook	<input type="checkbox"/> Capacity and duty rating EN13001-3-5, ISO 17440 (ASME B30.10) <input type="checkbox"/> Hook forging strength class V (DIN15400) <input type="checkbox"/> Reeving 02: Hook forging type RSN1 (DIN15401) <input type="checkbox"/> Reeving 04: Hook forging type HBC with hand grip, size 2.5 (DIN15401) <input type="checkbox"/> Safety latch
Rope reeving	<input type="checkbox"/> EN-GJS-700-3 cast iron rope guide incl. pressure roll for slack rope protection. Machinery hoists: pressure bar along the drum to hold the rope <input type="checkbox"/> EN-GJS-500-7 rope sheaves <input type="checkbox"/> Rope sheave / rope diameter ratio according to ISO M6 duty class as minimum
Travelling	<input type="checkbox"/> Low headroom trolley flange width range 100–490 mm <input type="checkbox"/> Normal headroom trolley flange width ranges - 02 reeving: 80 – 450 mm - 04 reeving: 80 – 450 mm <input type="checkbox"/> Medium double girder trolley rail gauges 1200, 1400, 1700, 2000 mm (depends on H.O.L.) <input type="checkbox"/> High mounted double girder trolley rail gauge 900, 1200, 1400, 1700, 2000 mm <input type="checkbox"/> One travel motor in trolley. In N-trolley the amount depends on reeving system <input type="checkbox"/> EN-GJS-500-7 cast iron flanged rail wheels, 2 driven by travelling machinery. The wheel groove width is 65 mm as standard for double girder trolley <input type="checkbox"/> 4 pcs rubber buffers <input type="checkbox"/> Jump-off protection in single girder trolleys (N, L) <input type="checkbox"/> Axle failure protection in both double and single girder trolleys
Travel machinery	<input type="checkbox"/> Frequency converter motor with compact brake, controller in hoist panel <input type="checkbox"/> Two adjustable speeds with ramp functions min. 5 m/min, max. 20 m/min (MS2-control) <input type="checkbox"/> S3 duty, 40 % ED
Electrical outfit	<input type="checkbox"/> Standard 3-phase voltages 50Hz: 220V*, 230V*, 240V*, 380V, 400V, 415V, 500V*, 525V* <input type="checkbox"/> Standard 3-phase voltages 60Hz: 220V*, 230V*, 240V*, 440V, 460V, 480V, 575V*, 600V* <input type="checkbox"/> (*additional price and delivery time) <input type="checkbox"/> Standard control voltages 48V / 50Hz, 115V / 50Hz or 60Hz, 230V / 50Hz or 60Hz <input type="checkbox"/> Assembly according to IEC standards <input type="checkbox"/> IP 55 / NEMA 3R steel control panel <input type="checkbox"/> Electricians for single hoist use in crane application (main contactor or control voltage transformer not included) <input type="checkbox"/> Plug in connectors for power supply and control cables
Environment	<input type="checkbox"/> Standard operating temperature range is +5°C...+40°C. Optional features can extend the temperature range to -20°C...+55°C. Special designs available on request for colder and hotter environments.
Surface treatment	<input type="checkbox"/> See Section 7 and 9 for details
Marking	<input type="checkbox"/> Hoist type plate incl. CE mark <input type="checkbox"/> Rope code sticker <input type="checkbox"/> Hoist stickers: brand name and type designation <input type="checkbox"/> Hook stickers: brand name and load
Documents	<input type="checkbox"/> 1 pcs Hoist Owner's Manual <input type="checkbox"/> Hoist test certificate <input type="checkbox"/> Wire rope certificate <input type="checkbox"/> Hook certificate
Delivery	<input type="checkbox"/> Wooden crate packing. Size according to the trolley <input type="checkbox"/> Anticorrosion plastics around the hoist

1.3 ND Standard features

Hoisting	<input type="checkbox"/> Strain gauge as overload protector <input type="checkbox"/> 4-step hoisting limit switch <input type="checkbox"/> ISO M4, 180 starts/h, 30% ED <input type="checkbox"/> ISO M5, 240 starts/h, 40% ED <input type="checkbox"/> ISO M6, 300 starts/h, 50% ED
Hoist motor	<input type="checkbox"/> Two-speed pole-change hoisting motor, 6:1 speed ratio <input type="checkbox"/> 300 starts/h, 60 % ED <input type="checkbox"/> H class insulation <input type="checkbox"/> IP55 protection <input type="checkbox"/> Klixon type bimetal switches for thermal protection
Hook	<input type="checkbox"/> Capacity and duty rating EN13001-3-5, ISO 17440 (ASME B30.10) <input type="checkbox"/> Hook forging strength class V (DIN15400) <input type="checkbox"/> Reeving 02: Hook forging type HBC with handgrip, size 2.5 (DIN15401) <input type="checkbox"/> Reeving 04: Hook forging type HBC with handgrip, size size 5 (DIN15401) <input type="checkbox"/> Reeving 22: Hook forging type RSN4 (DIN15401) <input type="checkbox"/> Reeving 06, 08, 24, 26 and 28: Hook forging type RSN6 (DIN15401) <input type="checkbox"/> Safety latch
Rope reeving	<input type="checkbox"/> EN-GJS-700-3 cast iron rope guide incl. pressure roll for slack rope protection. Machinery hoists: pressure bar along the drum to hold the rope <input type="checkbox"/> EN-GJS-500-7 rope sheaves <input type="checkbox"/> Rope sheave / rope diameter ratio according to ISO M6 duty class as minimum
Travelling	<input type="checkbox"/> Low headroom trolley flange width range 100 – 610 mm. <i>Factory settings max. width or package size</i> <input type="checkbox"/> Normal headroom trolley flange width ranges <ul style="list-style-type: none"> - 02 reeving: 80–610 mm - 04 reeving: 80–610 mm - 06 and 08 reeving: 80–610 mm - 22 and 24 reeving: 80-610 mm - 26 and 28 reeving: 80–610 mm <input type="checkbox"/> Medium double girder trolley rail gauges 1400, 1700, 2000, 2400 mm (depends on H.O.L. and rope reeving) <input type="checkbox"/> High mounted double girder trolley rail gauge 1200, 1400, 1700, 2000, 2400 mm <input type="checkbox"/> Low double girder trolley rail gauges 1400, 1700, 2000 mm (depends on H.O.L.) <input type="checkbox"/> Two travel motors in double girder trolley. In N-trolley the amount depends on reeving system <input type="checkbox"/> EN-GJS-500-7 cast iron flanged rail wheels, groove width 65 mm, 2 driven by travelling machineries <input type="checkbox"/> EN-GJS-500-7 cast iron flanged rail wheels, 2 driven by travelling machinery. The wheel groove width is 65 mm as standard for double girder trolley <input type="checkbox"/> 4 pcs rubber buffers <input type="checkbox"/> Jump-off protection in single girder trolleys (N, L) <input type="checkbox"/> Axle failure protection in both double and single girder trolleys
Travel machinery	<input type="checkbox"/> Frequency converter motor with compact brake, controller in hoist panel <input type="checkbox"/> Two adjustable speeds with ramp functions min. 5 m/min, max. 20 m/min (MS2-control) <input type="checkbox"/> S3 duty, 40 % ED
Electrical outfit	<input type="checkbox"/> Standard 3-phase voltages 50Hz: 220V*, 230V*, 240V*, 380V, 400V, 415V, 500V*, 525V* <input type="checkbox"/> Standard 3-phase voltages 60Hz: 220V*, 230V*, 240V*, 440V, 460V, 480V, 575V*, 600V* <input type="checkbox"/> (*additional price and delivery time) <input type="checkbox"/> Standard control voltages 48V / 50Hz, 115V / 50Hz or 60Hz, 230V / 50Hz or 60Hz <input type="checkbox"/> Assembly according to IEC standards <input type="checkbox"/> IP 55 / NEMA 3R steel control panel <input type="checkbox"/> Electrics for single hoist use in crane application (main contactor or control voltage transformer not included) <input type="checkbox"/> Plug in connectors for power supply and control cables
Environment	<input type="checkbox"/> Standard operating temperature range is +5°C...+40°C. <input type="checkbox"/> Optional features can extend the temperature range to -20°C...+55°C. Special designs available on request for colder and hotter environments.
Surface treatment	<input type="checkbox"/> See Section 7 and 9 for details
Marking	<input type="checkbox"/> Hoist type plate <input type="checkbox"/> Rope code sticker <input type="checkbox"/> Hoist stickers: brand name and type designation <input type="checkbox"/> Hook stickers: brand name and load
Documents	<input type="checkbox"/> 1 pcs Hoist Owner's Manual <input type="checkbox"/> Hoist test certificate <input type="checkbox"/> Wire rope certificate <input type="checkbox"/> Hook certificate
Delivery	<input type="checkbox"/> Wooden crate packing. Size according to the trolley <input type="checkbox"/> Anticorrosion plastics around the hoist

1.4 NE Standard features

Hoisting	<input type="checkbox"/> Strain gauge as overload protector <input type="checkbox"/> 4-step hoisting limit switch <input type="checkbox"/> ISO M4, 180 starts/h, 30% ED <input type="checkbox"/> ISO M5, 240 starts/h, 40% ED <input type="checkbox"/> ISO M6, 300 starts/h, 50% ED
Hoist motor	<input type="checkbox"/> Two-speed pole-change hoisting motor, 6:1 speed ratio <input type="checkbox"/> 300 starts/h, 60 % ED <input type="checkbox"/> H class insulation <input type="checkbox"/> IP55 protection <input type="checkbox"/> Klixon type bimetal switches for thermal protection
Hook	<input type="checkbox"/> Capacity and duty rating EN13001-3-5, ISO 17440 (ASME B30.10) <input type="checkbox"/> Reeving 02, 04, 22, 24: Hook forging type HBC with hand grip, size 5 (DIN15401), strength class V (DIN15400) <input type="checkbox"/> Reeving 06 and 26: Hook forging type RSN10 (DIN15401), strength class T (DIN15400) <input type="checkbox"/> Reeving 06 and 28: Hook forging type RSN16 (DIN15401), strength class T (DIN15400) <input type="checkbox"/> Safety latch
Rope reeving	<input type="checkbox"/> EN-GJS-700-3 cast iron rope guide. Machinery hoists: pressure bar along the drum to hold the rope <input type="checkbox"/> EN-GJS-500-7 rope sheaves <input type="checkbox"/> Rope sheave / rope diameter ratio according to ISO M6 duty class as minimum
Travelling	<input type="checkbox"/> Normal headroom trolley flange width ranges <ul style="list-style-type: none"> - 02 reeving: 120-610 mm - 04 and 06 reeving: 120-610 mm - 22 and 24 reeving: 120-610 mm - 26 and 28 reeving: 120-610 mm <input type="checkbox"/> Medium double girder trolley rail gauges 1400, 1700, 2000, 2400, 2700, 3100, 3400, 3800 and 4200 mm (depends on H.O.L. and rope reeving) <input type="checkbox"/> Two travel motors in double girder trolley. In N-trolley the amount depends on reeving system <input type="checkbox"/> EN-GJS-500-7 cast iron flanged rail wheels, groove width 65 mm, 2 driven by travelling machineries <input type="checkbox"/> 4 pcs rubber buffers <input type="checkbox"/> Jump-off and axle failure protection in single girder trolleys (trolley type N)
Travel machinery	<input type="checkbox"/> Frequency converter motor, controller in hoist panel <input type="checkbox"/> Two adjustable speeds with ramp functions min. 5 m/min, max. 20 m/min (MS2-control) <input type="checkbox"/> S3 duty, 40 % ED
Electrical outfit	<input type="checkbox"/> Standard 3-phase voltages 50Hz: 220V*, 230V*, 240V*, 380V, 400V, 415V, 500V*, 525V* <input type="checkbox"/> Standard 3-phase voltages 60Hz: 220V*, 230V*, 240V*, 440V, 460V, 480V, 575V*, 600V* <input type="checkbox"/> (*additional price and delivery time) <input type="checkbox"/> Standard control voltages 48V / 50Hz, 115V / 50Hz or 60Hz, 230V / 50Hz or 60Hz <input type="checkbox"/> Assembly according to IEC standards <input type="checkbox"/> IP 55 / NEMA 3R steel control panel <input type="checkbox"/> Electrics for single hoist use in crane application (main contactor or control voltage transformer not included) <input type="checkbox"/> Plug in connectors for power supply and control cables
Environment	<input type="checkbox"/> Standard operating temperature range is +5°C...+40°C. Optional features can extend the temperature range to -20°C...+55°C. Special designs available on request for colder and hotter environments.
Surface treatment	<input type="checkbox"/> See Section 7 and 9 for details
Marking	<input type="checkbox"/> Hoist type plate <input type="checkbox"/> Rope code sticker <input type="checkbox"/> Hoist stickers: brand name and type designation <input type="checkbox"/> Hook stickers: brand name and load
Documents	<input type="checkbox"/> 1 pcs Hoist Owner's Manual <input type="checkbox"/> Hoist test certificate <input type="checkbox"/> Wire rope certificate <input type="checkbox"/> Hook certificate
Delivery	<input type="checkbox"/> Wooden crate packing. Size according to the trolley <input type="checkbox"/> Anticorrosion plastics around the hoist

1.5 NF Standard features

Hoisting	<input type="checkbox"/> Strain gauge as overload protector <input type="checkbox"/> 4-step hoisting limit switch <input type="checkbox"/> ISO M4, 180 starts/h, 30% ED <input type="checkbox"/> ISO M5, 240 starts/h, 40% ED <input type="checkbox"/> ISO M6, 300 starts/h, 50% ED
Hoist motor	<input type="checkbox"/> 2 pcs two-speed pole-change hoisting motor, 6:1 speed ratio <input type="checkbox"/> 300 starts/h, 60 % ED <input type="checkbox"/> H class insulation <input type="checkbox"/> IP55 protection <input type="checkbox"/> Klixon type bimetal switches for thermal protection
Hook	<input type="checkbox"/> Capacity and duty rating EN13001-3-5, ISO 17440 (ASME B30.10) <input type="checkbox"/> Reeving 22: Hook forging type HBC with hand grip, size 5 (DIN15401), strength class V (DIN15400) <input type="checkbox"/> Reeving 24: Hook forging type RSN16 (DIN15401), strength class T (DIN15400) <input type="checkbox"/> Reeving 26: Hook forging type RFN20 (DIN15401), strength class T (DIN15400) <input type="checkbox"/> Reeving 28: Hook forging type RFN25 (DIN15401), strength class T (DIN15400) <input type="checkbox"/> Safety latch
Rope reeving	<input type="checkbox"/> True vertical rope reeving <input type="checkbox"/> EN-GJS-700-3 cast iron rope guide. Machinery hoists: pressure bar along the drum to hold the rope <input type="checkbox"/> EN-GJS-500-7 rope sheaves <input type="checkbox"/> Rope sheave / rope diameter ratio according to ISO M6 duty class as minimum
Travelling	<input type="checkbox"/> Medium double girder trolley rail gauges 1700, 2000, 2400, 2700, 3100, 3400, 3800 and 4200 mm (depends on H.O.L. and rope reeving) <input type="checkbox"/> Two travel motors in trolley <input type="checkbox"/> EN-GJS-500-7 cast iron flanged rail wheels, groove width 65 mm, 2 driven by travelling machineries <input type="checkbox"/> 4 pcs rubber buffers
Travel machinery	<input type="checkbox"/> Frequency converter motor, frequency converter controller in hoist panel <input type="checkbox"/> Two adjustable speeds with ramp functions min. 5 m/min, max. 20 m/min (MS2-control) <input type="checkbox"/> S3 duty, 40 % ED
Electrical outfit	<input type="checkbox"/> Standard 3-phase voltages 50Hz: 220V*, 230V*, 240V*, 380V, 400V, 415V, 500V*, 525V* <input type="checkbox"/> Standard 3-phase voltages 60Hz: 220V*, 230V*, 240V*, 440V, 460V, 480V, 575V*, 600V* <input type="checkbox"/> (*additional price and delivery time) <input type="checkbox"/> Standard control voltages 48V / 50Hz, 115V / 50Hz or 60Hz, 230V / 50Hz or 60Hz <input type="checkbox"/> Assembly according to IEC standards <input type="checkbox"/> IP 55 / NEMA 3R steel control panel <input type="checkbox"/> Electrics for single hoist use in crane application (main contactor or control voltage transformer not included) <input type="checkbox"/> Plug in connectors for power supply and control cables
Environment	<input type="checkbox"/> Standard operating temperature range is +5°C...+40°C. Optional features can extend the temperature range to -20°C...+55°C. Special designs available on request for colder and hotter environments.
Surface treatment	<input type="checkbox"/> See Section 7 and 9 for details
Marking	<input type="checkbox"/> Hoist type plate <input type="checkbox"/> Rope code sticker <input type="checkbox"/> Hoist stickers: brand name and type designation <input type="checkbox"/> Hook stickers: brand name and load
Documents	<input type="checkbox"/> 1 pcs Hoist Owner's Manual <input type="checkbox"/> Hoist test certificate <input type="checkbox"/> Wire rope certificate <input type="checkbox"/> Hook certificate
Delivery	<input type="checkbox"/> Wooden crate packing. Size according to the trolley <input type="checkbox"/> Anticorrosion plastics around the hoist

1.6 SWF code example (SWF: Nova, Factory: Q)

N	B	04	L	5	A	F	P	2	35	A	T	1	N
	(GE09)	DES27	(DES01)	(DIM01)	GE08	HS06	HM01	HM02	(DIM03) (DIM05)	(HS03)	(TM01)	(EL05)	
1	2	3,4	5	6	7	8	9	10	11,12	13	14	15	16

Pos.	Code	Feature code	Feature	Available properties	
1	N		Short product name	N Nova hoist	
2	B	(GE09)	Frame size	<u>GE09 value</u> Z 243 mm rope drum diameter B 303 mm rope drum diameter C 355 mm rope drum diameter	<u>GE09 value</u> D 406 mm rope drum diameter E 608 mm rope drum diameter F 608 mm rope drum diameter (2 hoisting motors) C D E
3,4	04	DES27	Rope reeving code	<u>Reeving code</u> 0 1 rope fixed to drum 1 1 rope fixed to drum (in case of 10 rope falls) 2 2 ropes fixed to drum, true vertical A 1 x 6.7 rope on C frame drum B 1 x 8 mm rope on D frame drum	<u>Number of rope falls per Rope</u> 4 1 rope fall 2 2 rope falls per rope 4 4 rope falls per rope 6 6 rope falls per rope 8 8 rope falls per rope M1 = Machinery hoist, 1 rope fixed to drum, M2 = Machinery hoist, 2 ropes fixed to drum
5	L	(DES01)	Trolley type	<u>DES01 value</u> F Fixed hoist V Machinery hoist N Normal headroom trolley L Low headroom trolley J Special low headroom trolley X Special trolley	<u>DES01 value</u> H Double girder trolley high connection M Double girder trolley medium connection W Double girder trolley low connection A Two hoist trolley, main B Two hoist trolley, aux. T Twin hoist (common hook) H M W MA MB T
6	5	(DIM01)	Hoist duty group	<u>DIM01 value</u> 3 ISO M3 4 ISO M4 5 ISO M5	<u>DIM01 value</u> 6 ISO M6 X ISO M4 and load increased (6.3t, 12.5 t etc.) M6
7	A	GE08	Hoist drum length	A 310 mm rope drum length (if frame size Z, 394 mm) B 340 mm rope drum length (if frame size Z, 394 mm) C 440 mm rope drum length (if frame size Z, 504 mm) D 540 mm rope drum length E 660 mm rope drum length F 810 mm rope drum length G 1000 mm rope drum length H 1250 mm rope drum length	Z 1400 mm rope drum length J 1600 mm rope drum length K 1900 mm rope drum length L 2250 mm rope drum length M 2500 mm rope drum length N 2800 mm rope drum length X Special drum length
8	F	HS06	Hoisting gear type	E Hoist speed 4 m/min F Hoist speed 5 m/min G Hoist speed 6,3 m/min	H Hoist speed 8 m/min J Hoist speed 10 m/min Note: Speeds for 4 roped, 50Hz
9	P	HM01	Hoist motor type	A Frequency converter motor, ASR S Frequency converter motor, ESR P Pole change motor T Frequency converter motor	R Pole change motor 3:1 E Ex-proof pole change motor O Single speed motor C Cast iron pole change motor
10	2	HM02	Hoisting motor size	# 1-9 as motor power code (A, Z, X) (see technical guide)	
11,12	35	(DIM03) (DIM05)	Flange width/ Rail gauge	# Flange width (L / N trolleys) i.e. 350 mm = 35	# Rail gauge (D trolleys) i.e. 1200 mm = 12
13	A	(HS03)	Overload device	<u>HS03 value</u> A Mechanical limit switch B Strain gauge N No overload device MEC SG NO	<u>HS03 value</u> C Hoist power measurement D Mechanical limit switch and hoist power measure POW MECPOW
14	T	(TM01)	Trolley motor type	<u>TM01 value</u> N No trolley motor controls P Pole change motor E Ex-proof pole change motor P E	<u>TM01 value</u> O Single speed motor T Frequency converter motor C Steel frame motor O T C
15	1	(EL05)	Electric provisions	<u>EL05 value</u> 1 Single hoist for crane 2 Hoist for tandem use 3 Solo hoist 4 Hoist without electric controls CRANE TANDEM SOLO NO	<u>EL05 value</u> 5 Only condition monitoring unit 6 Hoist with universal bridge panel 7 Twin hoist use 8 Hoist with all crane electrics ECM UNV TWIN ALL
16	N		Special properties	N Standard hoist without any options F Options selected only from feature list	S Special properties

2 TECHNICAL CHARACTERISTICS

<p>P-series motors Pole change motors with two speeds.</p>
<p>A-series motors Frequency converter controlled motors with adaptive speed range (ASR). The lifting speed can be controlled by the operator, but the highest obtainable speed depends on the load. Nominal ASR speed can be reached at 100% load, and with lower loads the speed increases progressively, but is limited by the maximum ASR speed. The load where the maximum ASR speed can be reached is shown as a percentage of the hoist load.</p>
<p>S-series motors Frequency converter controlled motors with optional extended speed range (ESR). The lifting speed can be controlled by the operator. Without ESR enabled, the lifting speed is not affected by the load.</p> <p>With ESR enabled, the highest obtainable speed depends on the load. Nominal ESR speed can be reached at 100% load, and with lower loads the speed increases progressively, but is limited by the maximum ESR speed. The load where the maximum ESR speed can be reached is shown as a percentage of the hoist load. The difference to A-series is that the S-series motors have more power, so the nominal ESR speed is much higher than the nominal ASR speed and it is reached with higher loads.</p>

NOTICE	If the nominal ASR or ESR speed shown in the table exceeds the corresponding maximum speed, the maximum speed applies. The nominal values are automatically calculated and subject to unit conversion, so such discrepancies may occur.
---------------	---

Load (kg)	Frame	Falls	Trolleys						Duty ISO	Drum			Rope	Gear		P-series				A-series				S-series					
			L	N	M	W	H	F		Code	HOL (m)	Type		Ratio	Motor	Fixed speed (m/min)		tm / min	Motor	Adaptive Speed Range (m/min)			tm / min	Motor	Nominal Speed without ESR (m/min)	Extended Speed Range (m/min)			tm / min
																Low	High			Nom. ASR	Max. ASR	Max. ASR load %				Nom. ESR	Max. ESR	Max. ESR load %	
400	NB	M1						M6	A	24	B	F	134.2	P1	3.3	20	8	A3	21.7	30	50	9	S3	20	30	30	100	12	
									C	38		G	106	P2	4.2	25	10	A3	24.2	37.5	40	10	S3	25	37.5	37.5	100	15	
												H	87.7	P3	5.3	32	12.8	A3	27.4	48	32	11	S3	32	44.7	48	90	18	
400	NB	M2						M6	A	7	B	F	134.2	P1	3.3	20	8	A3	21.7	30	50	9	S3	20	30	30	100	12	
									C	15		G	106	P2	4.2	25	10	A3	24.2	37.5	40	10	S3	25	37.5	37.5	100	15	
												H	87.7	P3	5.3	32	12.8	A3	27.4	48	32	11	S3	32	44.7	48	90	18	
500	NB	M1						M6	A	24	B	F	134.2	P1	3.3	20	10	A3	19.4	30	40	10	S3	20	30	30	100	15	
									C	38		G	106	P2	4.2	25	12.5	A3	21.7	37.5	32	11	S3	25	35.4	37.5	90	18	
												H	87.7	P3	5.3	32	16	A3	24.5	48	25	12	S3	32	40	48	67	20	
500	NB	M2						M6	A	7	B	F	134.2	P1	3.3	20	10	A3	19.4	30	40	10	S3	20	30	30	100	15	
									C	15		G	106	P2	4.2	25	12.5	A3	21.7	37.5	32	11	S3	25	35.4	37.5	90	18	
												H	87.7	P3	5.3	32	16	A3	24.5	48	25	12	S3	32	40	48	67	20	
630	NB	M1						M6	A	24	B	F	134.2	P2	3.3	20	12	A3	17.3	30	32	11	S3	20	28.2	30	90	18	
									C	38		G	106	P2	4.2	25	15	A3	19.3	37.5	25	12	S3	25	31.5	37.5	80	20	
												H	87.7	P3	5.3	32	19.2	A3	19.8	48	20	12.5	S3	32	35.6	48	55	22	
630	NB	M2						M6	A	7	B	F	134.2	P2	3.3	20	12	A3	17.3	30	32	11	S3	20	28.2	30	90	18	
									C	15		G	106	P2	4.2	25	15	A3	19.3	37.5	25	12	S3	25	31.5	37.5	80	20	
												H	87.7	P3	5.3	32	19.2	A3	19.8	48	20	12.5	S3	32	35.6	48	55	22	
800	NB	M1						M5	A	24	B	F	134.2	P2	3.3	20	12	A3	15.3	30	25	12	S3	20	25	30	67	20	
									C	38		G	106	P2	4.2	25	15	A3	15.6	37.5	20	12.5	S3	25	28	37.5	55	22	
												H	87.7	P3	5.3	32	19.2	A3	15.6	48	16	12.5	S3	32	32	48	40	26	
800	NB	M2						M5	A	7	B	F	134.2	P2	3.3	20	12	A3	15.3	30	25	12	S3	20	25	30	67	20	
									C	15		G	106	P2	4.2	25	15	A3	15.6	37.5	20	12.5	S3	25	28	37.5	55	22	

Load (kg)	Frame	Falls	Trolleys						Duty ISO	Drum			Gear			P-series			A-series				S-series					
			L	N	M	W	H	F		Code	HOL (m)	Rope	Type	Ratio	Motor	Fixed speed (m/min)		tm / min	Motor	Adaptive Speed Range (m/min)			Motor	Nominal Speed without ESR (m/min)	Extended Speed Range (m/min)		tm / min	
																Low	High			Nom. ASR	Max. ASR	Max. ASR load %			Nom. ESR	Max. ESR		
																												ESR load %
											F	87.7	P3	5.3	32	19.2	A3	15.6	48	16	12.5	S3	32	32	48	40	26	
800	NB	02	L	N	M	H	F	M6	A	12	A	F	134.2	P1	1.7	10	6.3	A3	10.8	15	50	9	S3	10	15	15	100	12
									C	19																		
1000	NB	02	L	N	M	H	F	M6	A	12	A	F	134.2	P1	1.7	10	10	A3	9.7	15	40	10	S3	10	15	15	100	15
									C	19																		
1250	NB	02	L	N	M	H	F	M6	A	12	A	F	134.2	P2	1.7	10	12.5	A3	8.7	15	32	11	S3	10	14.1	15	90	18
									C	19		G	106	P2	2.1	12.5	16	A3	9.7	18.8	25	12	S3	12.5	15.8	18.8	70	20
												H	87.7	P3	2.7	16	20	A3	10	24	20	12.5	S3	16	17.9	24	55	22
1600	NB	02	L	N	M	H	F	M5	A	12	A	F	134.2	P2	1.7	10	16	A3	7.8	15	25	12.5	S3	10	12.5	15	67	20
									C	19		G	106	P2	2.1	12.5	20	A3	7.8	18.8	20	12.5	S3	12.5	14	18.8	55	22
												H	87.7	P3	2.7	16	25.6	A3	7.8	24	16	12.5	S3	16	16	24	40	26
1000	NB	04	L	N	M	H	F	M6	A	6	A	F	134.2	P1	0.8	5	5	A3	6.8	7.5	80	7	S3	5	7.5	7.5	100	8
									C	9.5		G	106	P2	1.1	6.3	6.3	A3	7.7	9.5	67	8	S3	6.3	9.5	9.5	100	9
												H	87.7	P3	1.3	8	8	A3	8.7	12	50	9	S3	8	12	12	100	12
1250	NB	04	L	N	M	H	F	M6	A	6	A	F	134.2	P1	0.8	5	6.3	A3	6.1	7.5	67	8	S3	5	7.5	7.5	100	9
									C	9.5		G	106	P2	1.1	6.3	8	A3	6.8	9.5	50	9	S3	6.3	9.5	9.5	100	12
												H	87.7	P3	1.3	8	10	A3	7.7	12	40	10	S3	8	12	12	100	15
1600	NB	04	L	N	M	H	F	M6	A	6	A	F	134.2	P1	0.8	5	8	A3	5.4	7.5	50	9	S3	5	7.5	7.5	100	12
									C	9.5		G	106	P2	1.1	6.3	10	A3	6.1	9.5	40	10	S3	6.3	9.5	9.5	100	15
												H	87.7	P3	1.3	8	12.8	A3	6.8	12	32	11	S3	8	11.2	12	90	18
2000	NB	04	L	N	M	H	F	M5	A	6	A	F	134.2	P1	0.8	5	10	A3	4.8	7.5	40	10	S3	5	7.5	7.5	100	15
									C	9.5																		
2000	NB	04	L	N	M	H	F	M6	A	6	A	F	134.2	P2	0.8	5	10	A3	4.8	7.5	40	10	S3	5	7.5	7.5	100	15
									C	9.5		G	106	P2	1.1	6.3	12.6	A3	5.4	9.5	32	11	S3	6.3	8.8	9.5	90	18
												H	87.7	P3	1.3	8	16	A3	6.1	12	25	12.5	S3	8	10	12	67	20
2500	NB	04	L	N	M	H	F	M6	A	6	A	F	134.2	P2	0.8	5	12.5	A3	4.3	7.5	32	11	S3	5	7.1	7.5	90	18
									C	9.5		G	106	P2	1.1	6.3	16	A3	4.8	9.5	25	12	S3	6.3	7.9	9.5	70	20
												H	87.7	P3	1.3	8	20	A3	5	12	20	12.5	S3	8	8.9	12	55	22
3200	NB	04	L	N	M	H	F	M5	A	6	A	F	134.2	P2	0.8	5	16	A3	3.9	7.5	25	12.5	S3	5	6.3	7.5	67	20
									C	9.5		G	106	P2	1.1	6.3	20	A3	3.9	9.5	20	12.5	S3	6.3	7	9.5	55	22
												H	87.7	P3	1.3	8	25.6	A3	3.9	12	16	12.5	S3	8	8	12	40	25
1000	NC	M1					V	M6	B	24	F	F	160.3	P3	3.3	20	20	A3	12.5	30	20	12.5	S3	20	22.4	30	55	22
									C	36	H	H	104.7	P4	5.3	32	32						S5	32	40	48	67	40
									D	48																		
									E	62																		
1000	NC	M2					V	M6	B	9.5	B	F	160.3	P3	3.3	20	20	A3	12.5	30	20	12.5	S3	20	22.4	30	55	22
									C	17	H	H	104.7	P4	5.3	32	32						S5	32	40	48	67	40

Load (kg)	Frame	Falls	Trolleys						Duty ISO	Drum		Rope	Gear		P-series			A-series			S-series																			
			L	N	M	W	H	F		V	Code		HOL (m)	Type	Ratio	Motor	Fixed speed (m/min)		tm / min	Motor	Adaptive Speed Range (m/min)			Motor	Nominal Speed without ESR (m/min)	Extended Speed Range (m/min)			tm / min											
																	Low	High			Nom. ASR	Max. ASR	Max. ASR load %			Nom. ESR	Max. ESR	Max. ESR load %												
				D	D	D			D	12																														
					N	M		H	F		E	15																												
5000	NC	04	L	N	M		H	F	M5	B	6	D	F	160.3	P3	0.8	5	25	A3	2.5	7.5	16	12.5	S3	5	5	7.5	40	25											
										C	9		H	104.7	P4	1.3	8	40					S5	8	8.9	12	55	45												
										D	12																													
										E	15																													
6300	NC	04	L		M		H	F	M4	B	6	D	E	192.6	P3	0.7	4	25	A3	2	6	16	12.5	S3	4	4	6	40	25											
										C	9																													
										D	12																													
										E	15				M	H	F																							
2000	ND	M1						V	M6	D	36	J	F	185.3	P5	3.3	20	40	A5	12.5	30	20	25	S5	20	22.4	30	55	45											
										E	48		H	113.8	P6	5.3	32	64					S7	32	40	48	70	80												
										F	64		J	94.3	P7	6.7	40	80																						
										G	82																													
2000	ND	M2						V	M6	D	18	F	F	185.3	P5	3.3	20	40	A5	12.5	30	20	25	S5	20	22.4	30	55	45											
										E	27		H	113.8	P6	5.3	32	64					S7	32	40	48	70	80												
										F	38		J	94.3	P7	6.7	40	80																						
										G	50																													
2500	ND	M1						V	M5	D	36	J	F	185.3	P5	3.3	20	50	A5	10	30	16	25	S5	20	20	30	40	50											
										E	48		H	113.8	P6	5.3	32	80					S7	32	35.8	48	55	90												
										F	64		J	94.3	P7	6.7	40	100					S7	40	N/A	N/A	N/A	100												
										G	82																													
2500	ND	M2						V	M5	D	18	F	F	185.3	P5	3.3	20	50	A5	10	30	16	25	S5	20	20	30	40	50											
										E	27		H	113.8	P6	5.3	32	80					S7	32	35.8	48	55	90												
										F	38		J	94.3	P7	6.7	40	100					S7	40	N/A	N/A	N/A	100												
										G	50																													
3150	ND	M1						V	M4	D	36	Z	E	223.8	P5	2.7	16	50	A5	8	24	16	25	S5	16	16	24	40	50											
										E	48																													
										F	64																													
										G	82																													
3150	ND	M2						V	M4	D	18	Y	E	223.8	P5	2.7	16	50	A5	8	24	16	25	S5	16	16	24	40	50											
										E	27																													
										F	38																													
										G	50																													
4000	ND	02	L	N	M	W	H	F	M6	D	18	G	F	185.3	P5	1.7	10	40	A5	6.3	15	20	25	S5	10	11.2	15	55	45											
										E	24		H	113.8	P6	2.7	16	64					S7	16	20	24	67	80												
										F	32	J	J	94.3	P7	3.3	20	80																						
										G	40	J																												
5000	ND	02	L	N	M	W	H	F	M5	D	18	G	F	185.3	P5	1.7	10	50	A5	5	15	16	25	S5	10	10	15	40	50											
										E	24		H	113.8	P6	2.7	16	80					S7	16	17.9	24	55	90												

Load (kg)	Frame	Falls	Trolleys						Duty ISO	Drum			Gear		P-series			A-series				S-series							
			L	N	M	W	H	F		Code	HOL (m)	Rope	Type	Ratio	Motor	Fixed speed (m/min)		tm / min	Motor	Adaptive Speed Range (m/min)			Motor	Nominal Speed without ESR (m/min)	Extended Speed Range (m/min)			tm / min	
																Low	High			Nom. ASR	Max. ASR	Max. ASR load %			Nom. ESR	Max. ESR	Max. ESR load %		
									F	32	J	J	94.3	P7	3.3	20	100						S7	20	N/A	N/A	N/A	100	
									G	40	J																		
6300	ND	02	L	N	M	W	H	F	M4	D	18	G	E	223.8	P5	1.3	8	50	A5	4	12	16	25	S5	8	8	12	40	50
									E	24																			
									F	32	Z																		
									G	40	Z																		
5000	ND	04	L	N	M	W	H	F	M6	D	9	G	F	185.3	P5	0.8	5	38	A5	4	7.5	25	25	S5	5	7.1	7.5	90	35
									E	12		H	113.8	P6	1.3	8	50						S7	8	12	12	100	60	
									F	16		J	94.3	P7	1.7	10	63												
									G	20																			
6300	ND	04	L	N	M	W	H	F	M6	D	9	G	F	185.3	P5	0.8	5	38	A5	4	7.5	25	25	S5	5	6.3	7.5	70	40
									E	12		H	113.8	P6	1.3	8	50						S7	8	11.3	12	90	70	
									F	16		J	94.3	P7	1.7	10	63												
									G	20																			
8000	ND	04	L	N	M	W	H	F	M6	D	9	G	F	185.3	P5	0.8	5	40	A5	3.2	7.5	20	25	S5	5	5.6	7.5	55	45
									E	12		H	113.8	P6	1.3	8	64						S7	8	10	12	67	80	
									F	16		J	94.3	P7	1.7	10	80												
									G	20																			
10000	ND	04	L	N	M	W	H	F	M5	D	9	G	F	185.3	P5	0.8	5	50	A5	2.5	7.5	16	25	S5	5	5	7.5	40	50
									E	12		H	113.8	P6	1.3	8	80						S7	8	8.9	12	55	90	
									F	16		J	94.3	P7	1.7	10	100						S7	10	N/A	N/A	N/A	100	
									G	20																			
12500	ND	04	L		M	W	H	F	M4	D	9	G	E	223.8	P5	0.7	4	50	A5	2	6	16	25	S5	4	4	6	40	50
									E	12																			
									F	16																			
									G	20																			
12000	ND	06		N	M	W	H	F	M6	D	6	H	F	185.3	P5	0.5	3.2	40	A5	2.1	4.8	20	25	S5	3.2	3.7	4.8	55	45
									E	8		H	113.8	P6	0.8	5	60						S7	5	6.7	7.5	67	80	
									F	10		J	94.3	P7	1.1	6.3	75												
									G	13																			
15000	ND	06		N	M	W	H	F	M5	D	6	H	F	185.3	P5	0.5	3.2	48	A5	1.7	4.8	16	25	S5	3.2	3.2	4.8	40	50
									E	8		H	113.8	P6	0.8	5	75						S7	5	6	7.5	55	90	
									F	10		J	94.3	P7	1.1	6.3	95						S7	6.3	N/A	N/A	N/A	95	
									G	13																			
16000	ND	08		N	M	W	H	F	M5	D	4.5	H	F	185.3	P5	0.4	2.5	40	A5	1.6	3.7	20	25	S5	2.5	2.8	3.7	55	45
									E	6		H	113.8	P6	0.7	4	64						S7	4	5	6	67	80	
									F	8		J	94.3	P7	0.8	5	80												
									G	10																			
20000	ND	08		N	M	W	H	F	M4	D	4.5	H	F	185.3	P5	0.4	2.5	50	A5	1.3	3.8	16	25	S5	2.5	2.5	3.7	40	50
									E	6		H	113.8	P6	0.7	4	80						S7	4	4.5	6	55	90	

Load (kg)	Frame	Falls	Trolleys						Duty ISO	Drum		Rope	Gear		P-series			A-series				S-series															
			L	N	M	W	H	F		V	Code		HOL (m)	Type	Ratio	Motor	Fixed speed (m/min)		tm / min	Motor	Adaptive Speed Range (m/min)			Motor	Nominal Speed without ESR (m/min)	Extended Speed Range (m/min)			tm / min								
																	Low	High			Nom. ASR	Max. ASR	Max. ASR load %			Nom. ESR	Max. ESR	Max. ESR load %									
									F	8		J	94.3	P7	0.8	5	100						S7	5	N/A	N/A	N/A	100									
4000	ND	22	N	M	W	H	F	M6	D	8.5	D	F	185.3	P5	1.7	10	40	A5	6.3	15	20	25	S5	10	11.2	15	55	45									
									E	13	+	H	113.8	P6	2.7	16	64	S7	16	20	24	67	80														
									F	18	Dr	J	94.3	P7	3.3	20	80																				
									G	25																											
									H	33.5																											
									J	46																											
5000	ND	22	N	M	W	H	F	M5	D	8.5	D	F	185.3	P5	1.7	10	50	A5	5	15	16	25	S5	10	10	15	40	50									
									E	13	+	H	113.8	P6	2.7	16	80	S7	16	17.9	24	55	90														
									F	18	Dr	J	94.3	P7	3.3	20	100	S7	20	N/A	N/A	N/A	100														
									G	25																											
									H	33.5																											
									J	46																											
6300	ND	24	N	M	W	H	F	M6	D	4	D	F	185.3	P5	0.8	5	32	A5	4	7.5	25	25	S5	5	6.3	7.5	70	40									
									E	6.5	+	H	113.8	P6	1.3	8	50	S7	8	11.3	12	90	70														
									F	9	Dr	J	94.3	P7	1.7	10	63																				
									G	12.5																											
									H	16.5																											
									J	23																											
8000	ND	24	N	M	W	H	F	M6	D	4	D	F	185.3	P5	0.8	5	40	A5	3.2	7.5	20	25	S5	5	5.6	7.5	55	45									
									E	6.5	+	H	113.8	P6	1.3	8	64	S7	8	10	12	67	80														
									F	9	Dr	J	94.3	P7	1.7	10	80																				
									G	12.5																											
									H	16.5																											
									J	23																											
10000	ND	24	N	M	W	H	F	M5	D	4	D	F	185.3	P5	0.8	5	50	A5	2.5	7.5	16	25	S5	5	5	7.5	40	50									
									E	6.5	+	H	113.8	P6	1.3	8	80	S7	8	8.9	12	55	90														
									F	9	Dr	J	94.3	P7	1.7	10	100	S7	10	N/A	N/A	N/A	100														
									G	12.5																											
									H	16.5																											
									J	23																											
12000	ND	26	N	M	W	H	F	M6	E	4	D	F	185.3	P5	0.5	3.2	38	A5	2.1	4.8	20	25	S5	3.2	3.7	4.8	55	45									
									F	6	+	H	113.8	P6	0.8	5	60	S7	5	6.7	7.5	67	80														
									G	8	Dr	J	94.3	P7	1.1	6.3	75																				
									H	11																											
									J	15																											

Load (kg)	Frame	Falls	Trolleys							Duty ISO	Drum			Rope	Gear		P-series				A-series				S-series										
			L	N	M	W	H	F	V		Code	HOL (m)	Type		Ratio	Motor	Fixed speed (m/min)		tm / min	Motor	Adaptive Speed Range (m/min)			Motor	Nominal Speed without ESR (m/min)	Extended Speed Range (m/min)			tm / min						
																	Low	High			Nom. ASR	Max. ASR	Max. ASR load %			Nom. ESR	Max. ESR	Max. ESR load %							
15000	ND	26		N	M	W	H	F	M5	E	4	D	F	185.3	P5	0.5	3.2	48	A5	1.7	4.8	16	25	S5	3.2	3.2	4.8	40	50						
										F	6	+	H	113.8	P6	0.8	5	75						S7	5	6	7.5	55	90						
										G	8	Dr	J	94.3	P7	1.1	6.3	95								S7	6.3	N/A	N/A	N/A	95				
										H	11																								
										J	15																								
16000	ND	28		N	M	W	H	F	M5	F	4.5	D	F	185.3	P5	0.4	2.5	40	A5	1.6	3.7	20	25	S5	2.5	2.8	3.7	55	45						
										G	6	+	H	113.8	P6	0.7	4	64							S7	4	5	6	67	80					
										H	8	Dr	J	94.3	P7	0.8	5	80																	
										J	11.5																								
20000	ND	28		N	M	W	H	F	M4	F	4.5	D	F	185.3	P5	0.4	2.5	50	A5	1.3	3.8	16	25	S5	2.5	2.5	3.7	40	50						
										G	6	+	H	113.8	P6	0.7	4	80								S7	4	4.5	6	55	90				
										H	8	Dr	J	94.3	P7	0.8	5	100									S7	5	N/A	N/A	N/A	100			
										J	11.5																								
3200	NE	M1						V	M6	C	32	M	E	344.9	P6	2.7	16	51	A7	16	24	32	50	S7	16	22.4	24	90	70						
										D	43		F	269.1	P6	3.3	20	64	A7	16	30	25	50	S7	20	25	30	70	80						
										E	56.5		G	223.1	P7	4	25	80						S8	25	31.3	37.5	70	100						
										F	73		H	184.1										S8	32	45.4	48	55	112						
										G	94.5		J	143.6										SA	40	50	60	70	160						
										H	122.5																								
										J	161.5																								
3200	NE	M2						V	M6	E	37	J	E	344.9	P6	2.7	16	51	A7	16	24	32	50	S7	16	22.4	24	90	70						
										F	48.5		F	269.1	P6	3.3	20	64	A7	16	30	25	50	S7	20	25	30	70	80						
										G	63		G	223.1	P7	4	25	80						S8	25	31.3	37.5	70	100						
										H	82		H	184.1										S8	32	45.4	48	55	112						
										J	108.5		J	143.6										SA	40	50	60	70	160						
										K	131.5																								
										L	158.5																								
										M	177.5																								
N	200.5																																		
4000	NE	M1						V	M5	C	32	M	E	344.9	P6	2.7	16	64	A7	12.5	24	25	50	S7	16	20	24	67	80						
										D	43		F	269.1	P6	3.3	20	80	A7	12.5	30	20	50	S7	20	22.4	30	55	90						
										E	56.5		G	223.1	P7	4	25	100						S8	25	28	37.5	55	112						
										F	73		H	184.1										S8	32	32	48	40	125						
										G	94.5		J	143.6										SA	40	44.7	60	55	180						
										H	122.5																								
										J	161.5																								

Load (kg)	Frame	Falls	Trolleys							Duty ISO	Drum		Rope	Gear		P-series			A-series				S-series						
			L	N	M	W	H	F	V		Code	HOL (m)		Type	Ratio	Motor	Fixed speed (m/min)		tm / min	Motor	Adaptive Speed Range (m/min)			Motor	Nominal Speed without ESR (m/min)	Extended Speed Range (m/min)			tm / min
																	Low	High			Nom. ASR	Max. ASR	Max. ASR load %			Nom. ESR	Max. ESR	Max. ESR load %	
4000	NE	M2						M5	E	37	J	E	344.9	P6	2.7	16	64	A7	12.5	24	25	50	S7	16	20	24	67	80	
									F	48.5	F	269.1	P6	3.3	20	80	A7	12.5	30	20	50	S7	20	22.4	30	55	90		
									G	63	G	223.1	P7	4	25	100	S8	25	28	37.5	55	112							
									H	82	H	184.1	S8	32	32	48	40	125											
									J	108.5	J	143.6	SA	40	44.7	60	55	180											
									K	131.5																			
									L	158.5																			
									M	177.5																			
									N	200.5																			
5000	NE	M1						M4	C	32	M	E	344.9	P6	2.7	16	80	A7	10	24	20	50	S7	16	17.9	24	55	90	
									D	43	F	269.1	P7	3.3	20	100	A7	10	30	16	50	S7	20	20	30	40	100		
									E	56.5	G	223.1	P8	4	25	125	S8	25	25	37.5	40	125							
									F	73	H	184.1	SA	32	35.8	48	55	180											
									G	94.5	J	143.6	SA	40	40	60	40	200											
									H	122.5																			
									J	161.5																			
									K	195																			
5000	NE	M2						M4	E	37	J	E	344.9	P6	2.7	16	80	A7	10	24	20	50	S7	16	17.9	24	55	90	
									F	48.5	F	269.1	P7	3.3	20	100	A7	10	30	16	50	S7	20	20	30	40	100		
									G	63	G	223.1	P8	4	25	125	S8	25	25	37.5	40	125							
									H	82	H	184.1	SA	32	35.8	48	55	180											
									J	108.5	J	143.6	SA	40	40	60	40	200											
									K	131.5																			
									L	158.5																			
									M	177.5																			
									N	200.5																			
6300	NE	02	N	M	F			M6	C	15.5	K	E	344.9	P6	1.3	8	50	A7	8	12	32	50	S7	8	11.3	12	90	70	
									D	21	F	269.1	P6	1.7	10	63	A7	8	15	25	50	S7	10	12.6	15	70	80		
									E	28	M	G	223.1	P7	2	12.5	79	S8	12.5	15.7	18.8	70	100						
									F	36	M	H	184.1	S8	16	17.8	24	55	112										
									G	47	M	J	143.6	SA	20	25.2	30	70	160										
									H	61	M																		
									J	80.5	M																		
									K	97	M																		

Load (kg)	Frame	Falls	Trolleys						Duty ISO	Drum			Gear			P-series					A-series					S-series				
			L	N	M	W	H	F		V	Code	HOL (m)	Rope	Type	Ratio	Motor	Fixed speed (m/min)		tm / min	Motor	Adaptive Speed Range (m/min)			tm / min	Motor	Nominal Speed without ESR (m/min)	Extended Speed Range (m/min)			tm / min
																	Low	High			Nom. ASR	Max. ASR	Max. ASR load %				Nom. ESR	Max. ESR	Max. ESR load %	
8000	NE	02	N	M	D	D	F	M5	C	15.5	K	E	344.9	P6	1.3	8	64	A7	6.3	12	25	50	S7	8	10	12	67	80		
									D	21	F	269.1	P6	1.7	10	80	A7	6.3	15	20	50	S7	10	11.2	15	55	90			
									E	28	M	G	223.1	P7	2	12.5	100					S8	12.5	14	18.8	55	112			
									F	36	M	H	184.1									S8	16	16	24	40	125			
									G	47	M	J	143.6									SA	20	22.4	30	55	180			
									H	61	M																			
									J	80.5	M																			
									K	97	M																			
10000	NE	02	N	M	D	D	F	M4	C	15.5	K	E	344.9	P6	1.3	8	80	A7	5	12	20	50	S7	8	8.9	12	55	90		
									D	21	F	269.1	P7	1.7	10	100	A7	5	15	16	50	S7	10	10	15	40	100			
									E	28	M	G	223.1	P8	2	12.5	125					S8	12.5	12.5	18.8	40	125			
									F	36	M	H	184.1									SA	16	17.9	24	55	180			
									G	47	M	J	143.6									SA	20	20	30	40	200			
									H	61	M																			
									J	80.5	M																			
									K	97	M																			
12500	NE	04	N	M	D	D	F	M6	C	7.5	K	E	344.9	P6	0.7	4	50	A7	4	6	32	50	S7	4	5.7	6	90	70		
									D	10.5	F	269.1	P6	0.8	5	63	A7	4	7.5	25	50	S7	5	6.3	7.5	70	80			
									E	14	M	G	223.1	P7	1.1	6.3	79					S8	6.3	7.9	9.5	70	100			
									F	18	M	H	184.1									S8	8	8.9	12	55	112			
									G	23.5	M	J	143.6									SA	10	12.5	15	70	160			
									H	30.5	M																			
									J	40	M																			
									K	48.5	M																			
16000	NE	04	N	M	D	D	F	M5	C	7.5	K	E	344.9	P6	0.6	4	64	A7	3.2	6	25	50	S7	4	5	6	67	80		
									D	10.5	F	269.1	P6	0.8	5	80	A7	3.2	7.5	20	50	S7	5	5.6	7.5	55	90			
									E	14	M	G	223.1	P7	1.1	6.3	101					S8	6.3	7	9.5	55	112			
									F	18	M	H	184.1									S8	8	8	12	40	125			
									G	23.5	M	J	143.6									SA	10	11.2	15	55	180			
									H	30.5	M																			
									J	40	M																			
									K	48.5	M																			
20000	NE	04	N	M	D	D	F	M4	C	7.5	K	E	344.9	P6	0.6	4	80	A7	2.5	6	20	50	S7	4	4.5	6	55	90		
									D	10.5	F	269.1	P7	0.8	5	100	A7	2.5	7.5	16	50	S7	5	5	7.5	40	100			
									E	14	M	G	223.1	P8	1.1	6.3	126					S8	6.3	6.3	9.5	40	125			
									F	18	M	H	184.1									SA	8	8.9	12	55	180			
									G	23.5	M	J	143.6									SA	10	10	15	40	200			
									H	30.5	M																			
									J	40	M																			
									K	48.5	M																			

Load (kg)	Frame	Falls	Trolleys						Duty ISO	Drum		Rope	Gear		P-series			A-series				S-series															
			L	N	M	W	H	F		V	Code		HOL (m)	Type	Ratio	Motor	Fixed speed (m/min)		tm / min	Motor	Adaptive Speed Range (m/min)			Motor	Nominal Speed without ESR (m/min)	Extended Speed Range (m/min)			tm / min								
																	Low	High			Nom. ASR	Max. ASR	Max. ASR load %			Nom. ESR	Max. ESR	Max. ESR load %									
20000	NE	06	N	M	H	F	V	M6	C	5	L	E	344.9	P6	0.4	2.5	50	A7	2.5	3.7	32	50	S7	2.5	3.5	3.7	80	70									
									D	7	F	269.1	P6	0.5	3.2	64	A7	2.5	4.8	25	50	S7	3.2	4.1	4.8	67	80										
									E	9	G	223.1	P7	0.7	4	80	S8	4	5.1	6	67	100															
									F	12	H	184.1	S8	5	5.8	7.5	55	115																			
									G	15.5	J	143.6	SA	6.3	8.2	9.5	67	160																			
									H	20																											
									J	26.5																											
									K	32																											
									25000	NE	06	N	M	H	F	V	M5	C	5	L	E	344.9	P6	0.4	2.5	63	A7	2	3.7	25	50	S7	2.5	3.3	3.7	67	80
																		D	7	F	269.1	P6	0.5	3.2	80	A7	2	4.8	20	50	S7	3.2	3.7	4.8	55	90	
E	9	G	223.1	P7	0.7	4	100	S8										4	4.6	6	55	112															
F	12	H	184.1	S8	5	5	7.5	40										125																			
G	15.5	J	143.6	SA	6.3	7.3	9.5	55										180																			
H	20																																				
J	26.5																																				
K	32																																				
30000	NE	06	N	M	H	F	V	M4										C	5	L	E	344.9	P6	0.4	2.5	75	A7	1.7	3.7	20	50	S7	2.5	3	3.7	55	90
																		D	7	F	269.1	P7	0.5	3.2	96	A7	1.7	4.8	16	50	S7	3.2	3.2	4.8	40	100	
									E	9	G	223.1	P8	0.7	4	120	S8	4	4	6	40	125															
									F	12	H	184.1	SA	5	6	7.5	55	180																			
									G	15.5	J	143.6	SA	6.3	6.3	9.5	40	200																			
									H	20																											
									J	26.5																											
									K	32																											
									32000	NE	08	M	F	V	M5	E	7	L	E	344.9	P6	0.3	2	64	A7	1.6	3	25	50	S7	2	2.5	3	67	80		
																F	9	F	269.1	P7	0.4	2.5	80	A7	1.6	3.7	20	50	S7	2.5	2.8	3.7	55	90			
G	11.5	G	223.1	S8	3.2	3.5	4.8	55								112																					
H	15	H	184.1	SA	4	5	6	67								160																					
J	20	J	143.6	SA	5	5.6	7.5	55								180																					
K	24																																				
40000	NE	08	M	F	V	M4	E	7	L	E	344.9	P6	0.3	2	80	A7	1.3	3	20	50	S7	2	2.2	3	55	90											
							F	9	F	269.1	P7	0.4	2.5	100	A7	1.3	3.7	16	50	S7	2.5	2.5	3.7	40	100												
							G	11.5	G	223.1	P8	0.5	3.2	128	S8	3.2	3.2	4.8	40	125																	
							H	15	H	184.1	SA	4	4.5	6	55	180																					
							J	20	J	143.6	SA	5	5	7.5	40	200																					
							K	24																													

Load (kg)	Frame	Falls	Trolleys						Duty ISO	Drum			Rope	Gear		P-series			A-series				S-series							
			L	N	M	W	H	F		V	Code	HOL (m)		Type	Ratio	Motor	Fixed speed (m/min)		tm / min	Motor	Adaptive Speed Range (m/min)			Motor	Nominal Speed without ESR (m/min)	Extended Speed Range (m/min)			tm / min	
																	Low	High			Nom. ASR	Max. ASR	Max. ASR load %			Nom. ESR	Max. ESR	Max. ESR load %		
6300	NE	22	N	M	D	D	D	F	M6	E	15	G	E	344.9	P6	1.3	8	50	A7	8	12	32	50	S7	8	11.3	12	90	70	
										F	21	+	F	269.1	P6	1.7	10	63	A7	8	15	25	50	S7	10	12.6	15	70	80	
										G	28.5	Gr	G	223.1	P7	2	12.5	79						S8	12.5	15.7	18.8	70	100	
										H	38		H	184.1										S8	16	17.8	24	55	112	
										J	51.5		J	143.6										SA	20	25.2	30	70	160	
										K	63.5																			
										L	77																			
										M	87																			
										N	98.5																			
8000	NE	22	N	M	D	D	D	F	M5	E	15	G	E	344.9	P6	1.3	8	64	A7	6.3	12	25	50	S7	8	10	12	67	80	
										F	21	+	F	269.1	P6	1.7	10	80	A7	6.3	15	20	50	S7	10	11.2	15	55	90	
										G	28.5	Gr	G	223.1	P7	2	12.5	100						S8	12.5	14	18.8	55	112	
										H	38		H	184.1										S8	16	16	24	40	125	
										J	51.5		J	143.6										SA	20	22.4	30	55	180	
										K	63.5																			
										L	77																			
										M	87																			
										N	98.5																			
10000	NE	22	N	M	D	D	D	F	M4	E	15	G	E	344.9	P6	1.3	8	80	A7	5	12	20	50	S7	8	8.9	12	55	90	
										F	21	+	F	269.1	P7	1.7	10	100	A7	5	15	16	50	S7	10	10	15	40	100	
										G	28.5	Gr	G	223.1	P8	2	12.5	125						S8	12.5	12.5	18.8	40	125	
										H	38		H	184.1										SA	16	17.9	24	55	180	
										J	51.5		J	143.6										SA	20	20	30	40	200	
										K	63.5																			
										L	77																			
										M	87																			
										N	98.5																			
12500	NE	24	N	M	D	D	D	F	M6	E	7.5	G	E	344.9	P6	0.7	4	50	A7	4	6	32	50	S7	4	5.7	6	90	70	
										F	10.5	+	F	269.1	P6	0.8	5	63	A7	4	7.5	25	50	S7	5	6.3	7.5	70	80	
										G	14	Gr	G	223.1	P7	1.1	6.3	79						S8	6.3	7.9	9.5	70	100	
										H	19		H	184.1										S8	8	8.9	12	55	112	
										J	25.5		J	143.6										SA	10	12.5	15	70	160	
										K	31.5																			
										L	38.5																			
										M	43.5																			
										N	49																			

Load (kg)	Frame	Falls	Trolleys						Duty ISO	Drum			Gear			P-series			A-series				S-series						
			L	N	M	W	H	F		V	Code	HOL (m)	Rope	Type	Ratio	Motor	Fixed speed (m/min)		tm / min	Motor	Adaptive Speed Range (m/min)			Motor	Nominal Speed without ESR (m/min)	Extended Speed Range (m/min)			tm / min
																	Low	High			Nom. ASR	Max. ASR	Max. ASR load %			Nom. ESR	Max. ESR	Max. ESR load %	
16000	NE	24	N	M	D	D	F	M5	E	7.5	G	E	344.9	P6	0.7	4	64	A7	3.2	6	25	50	S7	4	5	6	67	80	
									F	10.5	+	F	269.1	P6	0.8	5	80	A7	3.2	7.5	20	50	S7	5	5.6	7.5	55	90	
									G	14	Gr	G	223.1	P7	1.1	6.3	101						S8	6.3	7	9.5	55	112	
									H	19		H	184.1										S8	8	8	12	40	125	
									J	25.5		J	143.6										SA	10	11.2	15	55	180	
									K	31.5																			
									L	38.5																			
									M	43.5																			
20000	NE	24	N	M	D	D	F	M4	E	7.5	G	E	344.9	P6	0.6	4	80	A7	2.5	6	20	50	S7	4	4.5	6	55	90	
									F	10.5	+	F	269.1	P7	0.8	5	100	A7	2.5	7.5	16	50	S7	5	5	7.5	40	100	
									G	14	Gr	G	223.1	P8	1.1	6.3	126						S8	6.3	6.3	9.5	40	125	
									H	19		H	184.1										SA	8	8.9	12	55	180	
									J	25.5		J	143.6										SA	10	10	15	44	200	
									K	31.5																			
									L	38.5																			
									M	43.5																			
20000	NE	26	N	M	D	D	F	M6	E	5	G	E	344.9	P6	0.4	2.5	50	A7	2.5	3.7	32	50	S7	2.5	3.5	3.7	80	70	
									F	7	+	F	269.1	P6	0.5	3.2	64	A7	2.5	4.8	25	50	S7	3.2	4.1	4.8	67	80	
									G	9.5	Gr	G	223.1	P7	0.7	4	80						S8	4	5.1	6	67	100	
									H	12.5		H	184.1										S8	5	5.8	7.5	55	115	
									J	17		J	143.6										SA	6.3	8.2	9.5	67	160	
									K	21																			
									L	25.5																			
									M	28.5																			
25000	NE	26	N	M	D	D	F	M5	E	5	G	E	344.9	P6	0.4	2.5	63	A7	2	3.7	25	50	S7	2.5	3.3	3.7	67	80	
									F	7	+	F	269.1	P6	0.5	3.2	80	A7	2	4.8	20	50	S7	3.2	3.7	4.8	55	90	
									G	9.5	Gr	G	223.1	P7	0.7	4	100						S8	4	4.6	6	55	112	
									H	12.5		H	184.1										S8	5	5	7.5	40	125	
									J	17		J	143.6										SA	6.3	7.3	9.5	55	180	
									K	21																			
									L	25.5																			
									M	28.5																			

Load (kg)	Frame	Falls	Trolleys						Duty ISO	Drum			Gear		P-series				A-series				S-series						
			L	N	M	W	H	F		V	Code	HOL (m)	Rope	Type	Ratio	Motor	Fixed speed (m/min)		tm / min	Motor	Adaptive Speed Range (m/min)			Motor	Nominal Speed without ESR (m/min)	Extended Speed Range (m/min)			tm / min
																	Low	High			Nom. ASR	Max. ASR	Max. ASR load %			Nom. ESR	Max. ESR	Max. ESR load %	
30000	NE	26		N	M		F	M4	E	5	G	E	344.9	P6	0.4	2.5	75	A7	1.7	3.7	20	50	S7	2.5	3	3.7	55	90	
									F	7	+	F	269.1	P7	0.5	3.2	96	A7	1.7	4.8	16	50	S7	3.2	3.2	4.8	40	100	
									G	9.5	Gr	G	223.1	P8	0.7	4	120						S8	4	4	6	40	125	
									H	12.5		H	184.1										SA	5	6	7.5	55	180	
									J	17		J	143.6										SA	6.3	6.3	9.5	40	200	
									K	21																			
									L	25.5																			
									M	28.5																			
									N	32.5																			
32000	NE	28		N	M		F	M5	F	5	G	E	344.9	P6	0.3	2	64	A7	1.6	3	25	50	S7	2	2.5	3	67	80	
									G	7	+	F	269.1	P7	0.4	2.5	80	A7	1.6	3.7	20	50	S7	2.5	2.8	3.7	55	90	
									H	9.5	Gr	G	223.1										S8	3.2	3.5	4.8	55	112	
									J	12.5		H	184.1										SA	4	5	6	67	160	
									K	15.5		J	143.6										SA	5	5.6	7.5	55	180	
									L	19																			
									M	21.5																			
									N	24.5																			
									40000	NE	28		N	M		F	M4	F	5	G	E	344.9	P6	0.3	2	80	A7	1.3	3
G	7	+	F	269.1	P7	0.4	2.5	100										A7	1.3	3.7	16	50	S7	2.5	2.5	3.7	40	100	
H	9.5	Gr	G	223.1	P8	0.5	3.2	128															S8	3.2	3.2	4.8	40	125	
J	12.5		H	184.1																			SA	4	4.5	6	55	180	
K	15.5		J	143.6																			SA	5	5	7.5	40	200	
L	19																												
M	21.5																												
N	24.5																												
12500	NF	22			M		F	M6										F	15.5	K	E	344.9	2P6	1.2	8	100	2A7	8	12
									G	20.5	+	F	269.1	2P6	1.6	10	125	2A7	8	15	25	100	2S7	10	12.6	15	70	160	
									H	27.5	Kr	G	223.1	2P7	2	12.5	157						2S8	12.5	15.8	18.8	70	200	
									J	37.5		H	184.1										2S8	16	17.9	24	55	225	
									K	46		J	143.6										2SA	20	25.3	30	70	315	
									L	55.5																			
									M	62.5																			
									N	71																			
									16000	NF	22			M		F	M5	F	15.5	K	E	344.9	2P6	1.2	8	128	2A7	6.3	12
G	20.5	+	F	269.1	2P6	1.6	10	160										2A7	6.3	15	20	100	2S7	10	11.2	15	55	180	
H	27.5	Kr	G	223.1	2P7	2	12.5	200															2S8	12.5	14	18.8	55	225	
J	37.5		H	184.1																			2S8	16	16	24	40	250	
K	46		J	143.6																			2SA	20	22.4	30	55	360	
L	55.5																												
M	62.5																												
N	71																												

Load (kg)	Frame	Falls	Trolleys						Duty ISO	Drum			Gear			P-series			A-series				S-series									
			L	N	M	W	H	F		Code	HOL (m)	Rope	Type	Ratio	Motor	Fixed speed (m/min)		tm / min	Motor	Adaptive Speed Range (m/min)			Motor	Nominal Speed without ESR (m/min)	Extended Speed Range (m/min)			tm / min				
																Low	High			Nom. ASR	Max. ASR	Max. ASR load %			Nom. ESR	Max. ESR	Max. ESR load %					
20000	NF	22			M	F	M4	F	15.5	K	E	344.9	2P6	1.2	8	160	2A7	5	12	20	100	2S7	8	8.9	12	55	180					
								G	20.5	+	F	269.1	2P7	1.6	10	200	2A7	5	15	16	100	2S7	10	10	15	40	200					
								H	27.5	Kr	G	223.1											2S8	12.5	12.5	18.8	40	250				
								J	37.5		H	184.1											2SA	16	17.9	24	55	360				
								K	46																							
								L	55.5																							
								M	62.5																							
								N	71																							
25000	NF	24			M	F	M6	F	7.5	K	E	344.9	2P6	0.6	4	100	2A7	4	6	32	100	2S7	4	5.7	6	90	140					
								G	10	+	F	269.1	2P6	0.8	5	125	2A7	4	7.5	25	100	2S7	5	6.3	7.5	70	160					
								H	13.5	Kr	G	223.1	2P7	1	6.3	158							2S8	6.3	8	9.5	70	200				
								J	18.5		H	184.1											2S8	8	9	12	55	225				
								K	23		J	143.6											2SA	10	12.5	15	70	315				
								L	27.5																							
								M	31																							
								N	35.5																							
32000	NF	24			M	F	M5	F	7.5	K	E	344.9	2P6	0.6	4	128	2A7	3.2	6	25	100	2S7	4	5	6	67	160					
								G	10	+	F	269.1	2P6	0.8	5	160	2A7	3.2	7.5	20	100	2S7	5	5.6	7.5	55	180					
								H	13.5	Kr	G	223.1	2P7	1	6.3	202							2S8	6.3	7	9.5	55	225				
								J	18.5		H	184.1											2S8	8	8	12	40	250				
								K	23		J	143.6											2SA	10	11.2	15	55	360				
								L	27.5																							
								M	31																							
								N	35.5																							
40000	NF	24			M	F	M4	F	7.5	K	E	344.9	2P6	0.6	4	160	2A7	2.5	6	20	100	2S7	4	4.5	6	55	180					
								G	10	+	F	269.1	2P7	0.8	5	200	2A7	2.5	7.5	16	100	2S7	5	5	7.5	40	200					
								H	13.5	Kr	G	223.1											2S8	6.3	6.3	9.5	40	250				
								J	18.5		H	184.1											2SA	8	8.9	12	55	360				
								K	23																							
								L	27.5																							
								M	31																							
								N	35.5																							
40000	NF	26			M	F	M6	F	5	L	E	344.9	2P6	0.4	2.5	100	2A7	2.5	4	32	100	2S7	2.5	3.7	4	80	150					
								G	6.5	+	F	269.1	2P6	0.5	3.2	128	2A7	2.5	5	25	100	2S7	3.2	4.1	4.8	67	160					
								H	9	Lr	G	223.1	2P7	0.6	4	160							2S8	4	5.1	6	67	200				
								J	12.5		H	184.1											2S8	5	6.6	7.5	55	260				
								K	15		J	143.6											2SA	6.3	8.2	9.5	67	330				
								L	18.5																							
								M	20.5																							
								N	23.5																							

Load (kg)	Frame	Falls	Trolleys						Duty ISO	Drum			Gear		P-series			A-series				S-series													
			L	N	M	W	H	F		V	Code	HOL (m)	Rope	Type	Ratio	Motor	Fixed speed (m/min)		tm / min	Motor	Adaptive Speed Range (m/min)			Motor	Nominal Speed without ESR (m/min)	Extended Speed Range (m/min)			tm / min						
																	Low	High			Nom. ASR	Max. ASR	Max. ASR load %			Nom. ESR	Max. ESR	Max. ESR load %							
50000	NF	26			M		F	M5	F	5	L	E	344.9	2P6	0.4	2.5	125	2A7	2	4	25	100	2S7	2.5	3.3	3.7	67	160							
									G	6.5	+	F	269.1	2P6	0.5	3.2	160	2A7	2	5	20	100	2S7	3.2	3.7	4.8	55	185							
									H	9	Lr	G	223.1	2P7	0.6	4	200							2S8	4	4.6	6	55	230						
									J	12.5		H	184.1											2S8	5	5	7.5	40	250						
									K	15		J	143.6											2SA	6.3	7.3	9.5	55	365						
									L	18.5																									
									M	20.5																									
									N	23.5																									
60000	NF	26			M		F	M4	F	5	L	E	344.9	2P6	0.4	2.5	150	2A7	1.7	4	20	100	2S7	2.5	3	3.7	55	180							
									G	6.5	+	F	269.1	2P7	0.5	3.2	192	2A7	1.7	5	16	100	2S7	3.2	3.2	4.8	40	200							
									H	9	Lr	G	223.1											2S8	4	4	6	40	250						
									J	12.5		H	184.1											2SA	5	6	7.5	55	360						
									K	15																									
									L	18.5																									
									M	20.5																									
									N	23.5																									
63000	NF	28			M		F	M5	H	6.5	L	E	344.9	2P6	0.3	2	126	2A7	1.6	3	25	100	2S7	2	2.5	3	67	160							
									J	9	+	F	269.1	2P6	0.4	2.5	158	2A7	1.6	3.8	20	100	2S7	2.5	2.8	3.8	55	180							
									K	11	Lr	G	223.1	2P7	0.5	3.2	200							2S8	3.2	3.5	4.8	55	220						
									L	13.5		H	184.1											2S8	4	4	6	40	250						
									M	15.5		J	143.6											2SA	5	5.6	7.5	55	360						
									N	17.5																									
80000	NF	28			M		F	M4	H	6.5	L	E	344.9	2P6	0.3	2	160	2A7	1.3	3	20	100	2S7	2	2.2	3	55	180							
									J	9	+	F	269.1	2P7	0.4	2.5	200	2A7	1.3	3.8	16	100	2S7	2.5	2.5	3.8	40	200							
									K	11	Lr	G	223.1											2S8	3.2	3.2	4.8	40	250						
									L	13.5		H	184.1											2SA	4	4.5	6	55	360						
									M	15.5																									
									N	17.5																									

3 HOISTING MOTORS

3.1 Hoisting motor data, two speed pole change motors, 50 Hz

Hoist	Hoisting motor rating	Characteristic	Unit	P1		P2		P3		P4		
				MF10M-106		MF10Z-106		MF10X-106		MF11XA106		
				High	Low	High	Low	High	Low	High	Low	
Standard hoist	300 Starts/h 60 % ED	Rated power	kW	1.8	0.25	3.6	0.5	4.5	0.7	7.5	1.2	
		Synchronous speed	rpm	3000	500	3000	500	3000	500	3000	500	500
		Brake torque	Nm	21		21		42		54		
		Max el. br. torque	Nm		32		63		77		105	
		El. br. torque	Nm		12.6		25		38		56	
		Power fact. start	-	0.8	0.83	0.83	0.78	0.84	0.77	0.79	0.69	
		Starting torque	Nm	12.4	10.7	25	22	34	28	57	48	
		Weight	kg	22.6		30.6		35		51		
		Brake inertia	kgm ²	0.00017		0.00017		0.00045		0.0007		
		Inertia w/o brake	kgm ²	0.0027		0.0049		0.0059		0.0101		
		Load	tm/min	10		20		25		40		
		Nominal power	kW	1.8	0.25	3.6	0.5	4.5	0.7	7.5	1.2	
		Nominal torque	Nm	6.1	6.1	12.3	12.3	15.3	15.3	24	24	
		Nominal speed	rpm	2780	420	2800	400	2750	415	2650	355	
		Short time duty	min	60	15	60	15	30	15	30	12	
		Power factor	-	0.82	0.67	0.87	0.63	0.92	0.61	0.90	0.56	
Efficiency	-	0.66	0.24	0.73	0.30	0.72	0.30	0.73	0.28			
Special application at lower load ratings	300 starts/h 60 % ED	Load	tm/min	10		20		25		40		
		Nominal power	kW	1.8	0.25	3.6	0.5	4.5	0.7	7.5	1.2	
		Nominal torque	Nm	6.1	6.1	12.3	12.3	15.3	15.3	24	24	
		Nominal speed	rpm	2780	420	2800	400	2750	415	2650	355	
		Short time duty	min	60	15	60	15	30	15	30	12	
		Power factor	-	0.82	0.67	0.87	0.63	0.92	0.61	0.90	0.56	
		Efficiency	-	0.66	0.24	0.73	0.30	0.72	0.30	0.73	0.28	
		Load	tm/min	8		16		20		32		
		Nominal power	kW	1.5	0.2	2.9	0.4	3.6	0.5	6	1	
		Nominal torque	Nm	4.9	4.9	9.8	9.8	12.3	12.3	19.2	19.2	
		Nominal speed	rpm	2830	435	2850	420	2830	430	2730	390	
		Short time duty	min									
		Power factor	-	0.78	0.64	0.84	0.58	0.89	0.56	0.87	0.52	
		Efficiency	-	0.64	0.22	0.76	0.29	0.74	0.29	0.74	0.27	
		Load	tm/min	6.3		12.5		16		25		
		Nominal power	kW	1.2	0.16	2.4	0.35	2.9	0.4	4.5	0.7	
		Nominal torque	Nm	3.9	3.9	7.7	7.7	9.8	9.8	15.3	15.3	
		Nominal speed	rpm	2860	445	2890	435	2870	440	2800	420	
		Short time duty	min									
		Power factor	-	0.73	0.61	0.77	0.53	0.85	0.51	0.82	0.47	
		Efficiency	-	0.61	0.18	0.75	0.26	0.73	0.27	0.75	0.26	
		Load	tm/min	5		10		12.5		20		
		Nominal power	kW	0.9	0.12	1.8	0.25	2.4	0.35	3.6	0.5	
		Nominal torque	Nm	3	3	6.1	6.1	7.7	7.7	12.3	12.3	
		Nominal speed	rpm	2890	460	2920	450	2900	450	2840	440	
		Short time duty	min									
		Power factor	-	0.66	0.58	0.69	0.50	0.81	0.48	0.76	0.45	
		Efficiency	-	0.58	0.15	0.73	0.23	0.72	0.24	0.74	0.23	

...Two speed pole change motors, 50 Hz, Continued

Hoist	Hoisting motor rating	Characteristic	Unit	P5		P6		P7		P8*		
				MF11X-106		MF13Z-106		MF13X-106		MF13XA106		
				High	Low	High	Low	High	Low	High	Low	
Standard hoist	300 Starts/h 60 % ED	Rated power	kW	9	1.4	15	2.5	18	3	23	3.5	
		Synchronous speed	rpm	3000	500	3000	500	3000	500	3000	500	500
		Brake torque	Nm	54		100		130		200		
		Max el. br. torque	Nm		107		190		225		290	
		El. br. torque	Nm		57		84		111		150	
		Power fact. start		0.77	0.69	0.67	0.68	0.62	0.65	0.73	0.67	
		Starting torque	Nm	67	56	107	84	120	111	165	140	
		Weight	kg	59		86		99		99		
		Brake inertia	kgm ²	0.0007		0.0007		0.0017		0.0017		
		Inertia w/o brake	kgm ²	0.0116		0.036		0.043		0.043		
		Load	tm/min	50		80		100		125		
		Nominal power	kW	9	1.4	15	2.5	18	3	23	3.5	
		Nominal torque	Nm	30	30	48	48	62	62	76	76	
		Nominal speed	rpm	2680	335	2740	420	2770	425	2790	420	
		Short time duty	min	30	10	30	15	30	15	15	10	
		Power factor	-	0.90	0.61	0.87	0.59	0.91	0.56	0.84	0.57	
Efficiency	-	0.72	0.28	0.78	0.45	0.80	0.47	0.83	0.44			
Special application at lower load ratings	300 starts/h 60 % ED	Load	tm/min	50		80		100				
		Nominal power	kW	9	1.4	15	2.5	18	3			
		Nominal torque	Nm	30	30	48	48	62	62			
		Nominal speed	rpm	2680	335	2740	420	2770	425			
		Short time duty	min	30	10	30	15	30	15			
		Power factor	-	0.90	0.61	0.87	0.59	0.91	0.56			
		Efficiency	-	0.72	0.28	0.78	0.45	0.80	0.47			
		Load	tm/min	40		63		80				
		Nominal power	kW	7.5	1.2	12	2	15	2.5			
		Nominal torque	Nm	24	24	38	38	48	48			
		Nominal speed	rpm	2760	370	2810	440	2820	440			
		Short time duty	min									
		Power factor	-	0.87	0.56	0.82	0.52	0.89	0.47			
		Efficiency	-	0.79	0.28	0.80	0.43	0.82	0.43			
		Load	tm/min	32		50		63				
		Nominal power	kW	6	1	9	1.4	12	2			
		Nominal torque	Nm	19.2	19.2	30	30	38	38			
		Nominal speed	rpm	2820	400	2860	455	2865	455			
		Short time duty	min									
		Power factor	-	0.84	0.52	0.78	0.48	0.87	0.41			
		Efficiency	-	0.79	0.28	0.80	0.41	0.82	0.40			
		Load	tm/min	25		40		50				
		Nominal power	kW	4.5	0.7	7.5	1.2	9	1.4			
		Nominal torque	Nm	15.3	15.3	24	24	30	30			
Nominal speed	rpm	2870	425	2900	465	2900	465					
Short time duty	min											
Power factor	-	0.80	0.47	0.70	0.42	0.84	0.36					
Efficiency	-	0.79	0.25	0.77	0.34	0.82	0.35					

*) Note! P8 hoisting motor for M4 use only. External fan as standard

3.2 Hoisting motor currents, two speed pole change motors, 50 Hz

Nominal voltage		230 V			400 V		500 V		660 V	
Used in voltage range		220...240 V			380...415 V		500...525 V		660...690 V	
		tm/min	Current (Amperes)		Current (Amperes)		Current (Amperes)		Current (Amperes)	
			High	Low	High	Low	High	Low	High	Low
P1 MF10M-106	Starting current	-	35	6.1	20	3.6	16	2.9	12	2.2
	Nominal current	10	8.5	4.9	4.9	2.8	3.9	2.2	3.0	1.7
		8	7.5	4.3	4.3	2.5	3.4	2.0	2.6	1.5
		6.3	7.0	4.3	4	2.5	3.2	2.0	2.4	1.5
	No-load current	-	6.3	4.9	3.6	2.8	2.9	2.2	2.2	1.7
P2 MF10Z-106	Starting current	-	68	11.7	39	6.7	31	5.4	24	4.1
	Nominal current	20	14	7.1	8.2	4.1	6.6	3.3	5.0	2.5
		16	12.2	6.6	7	3.8	5.6	3.0	4.2	2.3
		12.5	10.4	6.4	6	3.7	4.8	3.0	3.6	2.2
	No-load current	-	7.8	7.5	4.5	4.3	3.6	3.4	2.7	2.6
P3 MF10X-106	Starting current	-	77	15	44	8.6	35	6.9	27	5.2
	Nominal current	25	17	9.6	9.9	5.5	7.9	4.4	6.0	3.3
		20	14.6	8.7	8.4	5	6.7	4.0	5.1	3.0
		16	12.2	8.7	7	5	5.6	4.0	4.2	3.0
	No-load current	-	7.7	9.6	4.4	5.5	3.5	4.4	2.7	3.3
P4 MF11XA106	Starting current	-	118	22	68	12.7	54	10.2	41	7.7
	Nominal current	40	30	17	17	9.5	14	7.6	10	5.8
		32	24	15	13.7	8.6	11.0	6.9	8.3	5.2
		25	19	15	11	8.6	8.8	6.9	6.7	5.2
	No-load current	-	12	16	7.0	9.2	5.6	7.4	4.2	5.6
P5 MF11X-106	Starting current	-	144	28	83	16	66	12.8	50	9.7
	Nominal current	50	33	19	19	11	15	8.8	12	6.7
		40	28	16	16	9	13	7.2	9.9	5.5
		32	23	15	13.5	8.9	10.8	7.1	8.2	5.4
	No-load current	-	14	17	7.8	10	6.2	8.0	4.7	6.1
P6 MF13Z-106	Starting current	-	252	43	145	25	116	20	88	15
	Nominal current	80	56	24	32	14	26	11	19	8.5
		63	43	21	25	12	20	9.6	15	7.3
		50	38	21	22	12	18	9.6	13	7.3
	No-load current	-	28	23	16	13	13	10.4	9.7	7.9
P7 MF13X-106	Starting current	-	339	59	195	34	156	27.2	118	21
	Nominal current	100	66	31	38	18	30	14	23	11
		80	49	26	28	15	22	12.0	17	9.1
		63	40	26	23	15	18	12.0	14	9.1
	No-load current	-	21	31	12	18	9.6	14.4	7.3	10.9
P8 MF13XA106	Starting current	-	389	68	212	39	170	31	128	24
	Nominal current	125	85	40	49	23	39	18	30	14
	No-load current	-	43	38	25	22	20	18	15	13

3.3 Hoisting motor data, two speed pole change motors, 60 Hz

Hoist	Hoisting motor rating	Characteristic	Unit	P1		P2		P3		P4		
				MF10M-106		MF10Z-106		MF10X-106		MF11XA106		
				High	Low	High	Low	High	Low	High	Low	
Standard hoist	300 Starts/h 60 % ED	Rated power	kW	2.2	0.3	4.3	0.7	5.4	0.9	9	1.4	
		Synchronous speed	rpm	3600	600	3600	600	3600	600	3600	600	600
		Brake torque	Nm	21		21		42		54		
		Max el. br. torque	Nm		32		63		77		105	
		El. br. torque	Nm		12.6		25		38		56	
		Power fact. start	-	0.76	0.81	0.77	0.73	0.78	0.74	0.73	0.67	
		Starting torque	Nm	12.4	10.7	24.6	21.7	34	28	54	44	
		Weight	kg	22.6		30.6		35		51		
		Brake inertia	kgm ²	0.00017		0.00017		0.00045		0.0007		
		Inertia w/o brake	kgm ²	0.0027		0.0049		0.0059		0.0101		
		Load	tm/min	12		24		30		48		
		Nominal power	kW	2.2	0.3	4.3	0.7	5.4	0.9	9	1.4	
		Nominal torque	Nm	6.1	6.1	12.3	12.3	15.3	15.3	24	24	
		Nominal speed	rpm	3410	525	3400	500	3350	495	3230	450	
		Short time duty	min	60	15	60	15	30	15	30	12	
		Power factor	-	0.83	0.65	0.89	0.61	0.93	0.60	0.90	0.54	
		Efficiency	-	0.71	0.28	0.75	0.38	0.74	0.36	0.74	0.34	
Special application at lower load ratings	300 starts/h 60 % ED	Load	tm/min	12		24		30		48		
		Nominal power	kW	2.2	0.3	4.3	0.7	5.4	0.9	9	1.4	
		Nominal torque	Nm	6.1	6.1	12.3	12.3	15.3	15.3	24	24	
		Nominal speed	rpm	3410	525	3400	500	3350	495	3230	450	
		Short time duty	min	60	15	60	15	30	15	30	12	
		Power factor	-	0.83	0.65	0.89	0.61	0.93	0.60	0.90	0.54	
		Efficiency	-	0.71	0.28	0.75	0.38	0.74	0.36	0.74	0.34	
		Load	tm/min	9.6		19.2		24		38		
		Nominal power	kW	1.8	0.25	3.5	0.5	4.3	0.7	7.2	1.2	
		Nominal torque	Nm	4.9	4.9	9.8	9.8	12.3	12.3	19.2	19.2	
		Nominal speed	rpm	3450	540	3450	520	3410	530	3315	490	
		Short time duty	min									
		Power factor	-	0.80	0.58	0.87	0.54	0.91	0.53	0.88	0.49	
		Efficiency	-	0.71	0.25	0.75	0.36	0.75	0.34	0.76	0.33	
		Load	tm/min	7.6		15		19.2		30		
		Nominal power	kW	1.4	0.2	2.9	0.4	3.5	0.5	5.4	0.9	
		Nominal torque	Nm	3.9	3.9	7.7	7.7	9.8	9.8	15.3	15.3	
		Nominal speed	rpm	3480	550	3490	540	3450	540	3390	520	
		Short time duty	min									
		Power factor	-	0.75	0.55	0.82	0.49	0.88	0.49	0.85	0.43	
		Efficiency	-	0.68	0.21	0.74	0.31	0.75	0.31	0.75	0.31	
		Load	tm/min	6		12		15		24		
		Nominal power	kW	1.1	0.15	2.2	0.3	2.9	0.4	4.3	0.7	
		Nominal torque	Nm	3	3	6.1	6.1	7.7	7.7	12.3	12.3	
		Nominal speed	rpm	3510	565	3520	550	3490	550	3440	540	
		Short time duty	min									
		Power factor	-	0.67	0.52	0.76	0.45	0.85	0.45	0.78	0.39	
		Efficiency	-	0.66	0.18	0.71	0.28	0.73	0.28	0.74	0.28	

...Two speed pole change hoisting motors, 60 Hz, continued...

Hoist	Hoisting motor rating	Characteristic	Unit	P5		P6		P7		P8*		
				MF11X-106		MF13Z-106		MF13X-106		MF13XA106		
Standard hoist	300 Starts/h 60 % ED	Rated power	kW	11	1.6	18	3	21	3.5	25	3.8	
		Synchronous speed	rpm	3600	600	3600	600	3600	600	3600	600	
		Brake torque	Nm	54		100		130		200		
		Max el. br. torque	Nm		112		182		205		290	
		El. br. torque	Nm		64		82		101		150	
		Power fact. start	-	0.75	0.68	0.60	0.64	0.55	0.59	0.68	0.69	
		Starting torque	Nm	63	51	102	82	114	101	160	140	
		Weight	kg	59		86		99		99		
		Brake inertia	kgm ²	0.0007		0.0007		0.0017		0.0017		
		Inertia w/o brake	kgm ²	0.0116		0.036		0.043		0.043		
		Load	tm/min	60		96		120		135		
		Nominal power	kW	11	1.6	18	3	21	3.5	25	3.8	
		Nominal torque	Nm	30	30	48	48	62	62	69	69	
		Nominal speed	rpm	3250	440	3320	515	3360	520	3430	530	
		Short time duty	min	30	10	30	15	30	15	15	10	
		Power factor	-	0.91	0.57	0.88	0.59	0.92	0.55	0.87	0.54	
		Efficiency	-	0.75	0.35	0.80	0.50	0.81	0.52	0.86	0.49	
Special application at lower load ratings	300 starts/h 60 % ED	Load	tm/min	60		96		120				
		Nominal power	kW	11	1.6	18	3	21	3.5			
		Nominal torque	Nm	30	30	48	48	62	62			
		Nominal speed	rpm	3250	440	3320	515	3360	520			
		Short time duty	min	30	10	30	15	30	15			
		Power factor	-	0.91	0.57	0.88	0.59	0.92	0.55			
		Efficiency	-	0.75	0.35	0.80	0.50	0.81	0.52			
		Load	tm/min	48		76		96				
		Nominal power	kW	9	1.4	14	2.3	18	3			
		Nominal torque	Nm	24	24	38	38	48	48			
		Nominal speed	rpm	3320	470	3390	540	3410	540			
		Short time duty	min									
		Power factor	-	0.90	0.53	0.85	0.52	0.90	0.47			
		Efficiency	-	0.77	0.35	0.82	0.48	0.83	0.49			
		Load	tm/min	38		60		76				
		Nominal power	kW	7.2	1.2	11	1.6	14	2.3			
		Nominal torque	Nm	19.2	19.2	30	30	38	38			
		Nominal speed	rpm	3395	500	3445	555	3460	555			
		Short time duty	min									
		Power factor	-	0.87	0.47	0.82	0.48	0.88	0.41			
		Efficiency	-	0.77	0.34	0.82	0.46	0.83	0.46			
		Load	tm/min	30		48		60				
		Nominal power	kW	5.4	0.9	9	1.4	11	1.6			
		Nominal torque	Nm	15.3	15.3	24	24	30	30			
		Nominal speed	rpm	3450	525	3495	565	3495	565			
		Short time duty	min									
		Power factor	-	0.83	0.42	0.74	0.42	0.85	0.37			
Efficiency	-	0.77	0.31	0.82	0.39	0.83	0.41					

*) Note! P8 hoisting motor for M4 use only. External fan as standard.

3.4 Hoisting motor currents, two speed pole change motors, 60 Hz

Nominal voltage		220 V	380 V		460 V		575 V			
Used in voltage range		208...230 V	360...400 V		440...480 V		575...600 V			
	tm/min	Current (Amperes)		Current (Amperes)		Current (Amperes)		Current (Amperes)		
		High	Low	High	Low	High	Low	High	Low	
P1 MF10M-106	Starting current	-	42	9	23	4.7				
	Nominal current	12	9.8	5.9	5.0	3.4	4.7	2.8	3.6	2.2
		9.6	8.8	5.2	5.1	3.0	4.2	2.5	3.4	2.0
		7.6	7.9	5.2	4.6	3.0	3.8	2.5	3.0	2.0
	No-load current	6	7.1	5.2	4.1	3.0	3.4	2.5	2.7	2.0
	-	5.2	5.9	3	3.1	2.5	2.8	2	2.1	
P2 MF10Z-106	Starting current	-	90	15	52	8.8	43	7.3	34	5.8
	Nominal current	24	17	8.4	10	4.8	8.3	4.0	6.6	3.2
		19.2	15.3	8.2	8.8	4.7	7.3	3.9	5.8	3.1
		15	12.5	8.2	7.3	4.7	6	3.9	4.8	3.1
	No-load current	12	11.5	8.2	6.7	4.7	5.5	3.9	4.4	3.1
	-	7.9	8.6	4.6	5.0	3.8	4.1	3.0	3.3	
P3 MF10X-106	Starting current	-	102	18	59	10.2	49	8.4	39	6.7
	Nominal current	30	22	11	13	6.5	10	5.4	8.2	4.3
		24	18	10.2	10.3	5.9	8.5	4.9	6.8	3.9
		19.2	15	10.2	8.7	5.9	7.2	4.9	5.8	3.9
	No-load current	15	13	10.2	7.3	5.9	6	4.9	4.8	3.9
	-	8.4	11.3	4.8	6.5	4	5.4	3.2	4.3	
P4 MF11XA106	Starting current	-	146	29	85	17	70.0	14.0	56	11.2
	Nominal current	48	36	19	21	11	17	9.1	14	7.3
		38	27	17	16	10.0	13	8.3	10.4	6.6
		30	23	17	13	10.0	11	8.3	8.8	6.6
	No-load current	24	21	17	12	10.0	10	8.3	8.0	6.6
	-	12.5	18	7.3	10.7	6.0	8.8	4.8	7.0	
P5 MF11X-106	Starting current	-	167	31	97	18.2	80	15	64	12.0
	Nominal current	60	42	21	24	12	20	10	16	8.0
		49	33	18	19	10.5	16	8.7	12.8	7.0
		39	28	18	16	10.3	13.5	8.5	10.8	6.8
	No-load current	30	23	18	13	10.3	11	8.5	8.8	6.8
	-	14	20	8.1	11.5	6.7	9.5	5.4	7.6	
P6 MF13Z-106	Starting current	-	312	52	180	30	149	25	119	20
	Nominal current	96	67	27	39	16	32	13	26	10
		76	54	27	31	15.7	26	13	21	10.4
		60	46	25	27	14.5	22	12	18	9.6
	No-load current	48	36	25	21	14.5	17	12	13.6	9.6
	-	27	25	16	14.5	13	12	10.4	9.6	
P7 MF13X-106	Starting current	-	433	73	251	42	207	35	166	28
	Nominal current	120	79	33	46	19	38	16	30	13
		96	59	29	34	17	28	14	22	11.2
		76	46	29	27	17	22	14	18	11.2
	No-load current	60	40	29	23	17	19	14	15	11.2
	-	21	33	12	19	10	16	8.0	12.8	
P8 MF13XA106	Starting current	-	460	121	266	70	220	35	176	28
	Nominal current	135	98	47	57	27	47	22	38	18
	No-load current	-	40	41	23	24	19	20	15.2	16

3.5 Hoisting motor data, frequency converter motors, 50 Hz and 60 Hz

Hoist	Hoisting motor rating	Characteristic	Unit	50 Hz			60 Hz		
				A3	A5	A7	A3	A5	A7
				MF10ZK200	MF11MK200	MF13ZK200	MF10ZK200	MF11MK200	MF13ZK200
Standard hoist	300 Starts/h 60 % ED	Rated power	kW	2.25	4.5	9	2.7	5.4	11
		Synchronous speed	rpm	1500	1500	1500	1800	1800	1800
		Max. ESR	rpm	4500	4500	4500	4500	4500	4500
		Brake torque	Nm	42	60	130	42	60	130
		Brake type	-	NM38730NR2	NM40940NR2	NM40951NR2	NM38730NR2	NM40940NR2	NM40951NR2
		Pull-out torque	Nm	40	100	230	40	100	230
		Speed at pull-out torque	rpm	800	990	1030	1100	1290	1330
		Speed at 80% pull-out torque	rpm	1090	1230	1270	1390	1530	1570
		Starting torque	Nm	45	75	110	45	75	110
		Weight	kg	31	37	72	31	37	72
		Brake inertia	kgm ²	0.00045	0.0007	0.0017	0.00045	0.0007	0.0017
		Inertia w/o brake	kgm ²	0.0049	0.0075	0.030	0.0049	0.0075	0.030
		Iron losses	W	175	370	520	175	370	520
		Stator resistance	Ohm	4.0	1.8	0.7	4.0	1.8	0.7
Special application at lower load ratings	300 starts/h 60 % ED	Load	tm/min	12.5	25	50	15	30	60
		Nominal power	kW	2.25	4.5	9	2.7	5.4	11
		Nominal torque	Nm	15	30	60	15	30	60
		Nominal speed	rpm	1350	1390	1420	1650	1700	1730
		Short time duty	min	60	60	60	60	60	60
		Power factor	-	0.81	0.75	0.82	0.83	0.70	0.80
		Efficiency	-	0.76	0.84	0.86	0.76	0.85	0.88

3.6 Hoisting motor currents, frequency converter motors, 50 Hz and 60 Hz

		50Hz		60Hz	
Nominal voltage		400 V		460 V	
Used in voltage range		380...415 V		440...480 V	
		tm/min	Current (Amperes)	tm/min	Current (Amperes)
A3 MF10ZK200	Current at 80% of pull-out torque	-	11	-	12
	Nominal current	12.5	5.3	15	5.5
	No-load current	-	2.9	-	2.7
A5 MF11MK200	Current at 80% of pull-out torque	-	25	-	27
	Nominal current	25	11.5	30	11.5
	No-load current	-	9.0	-	8.9
A7 MF13ZK200	Current at 80% of pull-out torque	-	58	-	60
	Nominal current	50	20	60	20
	No-load current	-	12	-	12

3.7 Hoisting motor data, frequency converter motors, 100 Hz

Hoist	Hoisting motor rating	Characteristic	Unit	S3	S5	S7	S8	SA
				MF10ML200	MF11ML200	MF13ZL200	MF13ZJ200	MF13XL200
Standard hoist	300 Starts/h 60 % ED	Rated power	kW	4.5	9	18	23	35
		Synchronous speed	rpm	3000	3000	3000	3000	3000
		Max. ESR	rpm	4500	4500	4500	4500	4500
		Brake torque	Nm	42	60	130	200	200
		Brake type	-	NM38730NR2	NM40940NR2	NM40951NR2	NM40980NR2	NM40980NR2
		Pull-out torque	Nm	40	80	200	200	350
		Speed at pull-out torque	rpm	1670	2230	1830	1830	2260
		Speed at 80% pull-out torque	rpm	2410	2500	2720	2720	2750
		Starting torque	Nm	34	64	115	115	220
		Pull-out torque	Nm	40	80	200	200	350
		Speed at 80% pull-out torque	rpm	2410	2500	2720	2720	2750
		Weight	kg	23	37	72	72	99
		Brake inertia	kgm ²	0.00045	0.0007	0.0017	0.0017	0.0017
		Inertia w/o brake	kgm ²	0.0027	0.0075	0.030	0.030	0.043
		Iron losses	W	160	260	260	260	390
		Stator resistance	Ohm	2.0	0.65	0.25	0.25	0.13
		Load	tm/min	25	50	100	125	200
		Nominal power	kW	4.5	9	18	23	35
		Nominal torque	Nm	15.3	30	62	76	116
		Nominal speed	rpm	2780	2830	2910	2890	2880
Short time duty	min	60	30	30	30	30		
Power factor	-	0.78	0.78	0.86	0.88	0.85		
Efficiency	-	0.77	0.81	0.89	0.89	0.90		
Special application at lower load ratings	300 starts/h 60 % ED	Load	tm/min	20	40	80	100	160
		Nominal power	kW	3.6	7.5	15	18	28
		Nominal torque	Nm	12.3	24	48	62	96
		Nominal speed	rpm	2830	2860	2930	2910	2930
		Short time duty	min	-	-	-	-	-
		Power factor	-	0.72	0.74	0.82	0.86	0.83
		Efficiency	-	0.77	0.81	0.89	0.89	0.89
		Load	tm/min	16	32	63	80	125
		Nominal power	kW	2.9	6	12	15	23
		Nominal torque	Nm	9.8	19.2	38	48	76
		Nominal speed	rpm	2880	2900	2940	2930	2940
		Short time duty	min	-	-	-	-	-
		Power factor	-	0.65	0.67	0.77	0.82	0.78
		Efficiency	-	0.76	0.80	0.88	0.89	0.89
		Load	tm/min	12.5	25	50	63	100
		Nominal power	kW	2.4	4.5	9	12	18
		Nominal torque	Nm	7.7	15.3	30	38	62
		Nominal speed	rpm	2905	2925	2950	2940	2950
		Short time duty	min	-	-	-	-	-
		Power factor	-	0.58	0.61	0.72	0.77	0.73
Efficiency	-	0.74	0.78	0.84	0.88	0.88		
External Fan	Type		NM901NR10	NM901NR20	NM901NR30	NM901NR30	NM901NR30	
	Voltage range	3~ 50Hz	220-290V D	220-290V D	220-290V D	220-290V D	220-290V D	
		3~ 60Hz	380-500V Y	380-500V Y	380-500V Y	380-500V Y	380-500V Y	
	Current	3~ 50Hz	0.35A D	0.33A D	0.45A D	0.45A D	0.45A D	
3~ 60Hz		0.19A Y	0.18A Y	0.24A Y	0.24A Y	0.24A Y		

3.8 Hoisting motor data, frequency converter motors, 120 Hz

Hoist	Hoisting motor rating	Characteristic	Unit	S3	S5	S7	S8	SA
				MF10ML200	MF11ML200	MF13ZL200	MF13ZJ200	MF13XL200
Standard hoist	300 Starts/h 60 % ED	Rated power	kW	5.4	11	21	27	42
		Synchronous speed	rpm	3600	3600	3600	3600	3600
		Max. ESR	rpm	4500	4500	4500	4500	4500
		Brake torque	Nm	42	60	130	200	200
		Brake type	-	NM38730NR2	NM40940NR2	NM40951NR2	NM40980NR2	NM40980NR2
		Pull-out torque	Nm	39	76	190	190	335
		Speed at pull-out torque	rpm	2300	2830	2370	2370	2760
		Speed at 80% pull-out torque	rpm	3040	3100	3260	3260	3250
		Starting torque	Nm	34	64	115	115	220
		Weight	kg	23	37	72	72	99
		Brake inertia	kgm ²	0.00045	0.0007	0.0017	0.0017	0.0017
		Inertia w/o brake	kgm ²	0.0027	0.0075	0.030	0.030	0.043
		Iron losses	W	160	260	260	260	390
		Stator resistance	Ohm	2.0	0.65	0.25	0.25	0.13
		Load	tm/min	30	60	120	150	240
		Nominal power	kW	5.4	11	21	27	41
		Nominal torque	Nm	15.3	30	62	76	116
		Nominal speed	rpm	3340	3410	3500	3470	3470
		Short time duty	min	60	30	30	30	30
		Power factor	-	0.80	0.78	0.86	0.88	0.87
Efficiency	-	0.77	0.81	0.89	0.89	0.89		
Special application at lower load ratings	300 starts/h 60 % ED	Load	tm/min	24	48	96	120	192
		Nominal power	kW	4.3	9	18	21	34
		Nominal torque	Nm	12.3	24	48	62	96
		Nominal speed	rpm	3390	3440	3520	3500	3500
		Short time duty	min	-	-	-	-	-
		Power factor	-	0.76	0.75	0.84	0.86	0.86
		Efficiency	-	0.77	0.78	0.89	0.89	0.89
		Load	tm/min	19.2	38	76	96	150
		Nominal power	kW	3.5	7.2	14	18	27
		Nominal torque	Nm	9.8	19.2	38	48	76
		Nominal speed	rpm	3430	3485	3540	3520	3520
		Short time duty	min	-	-	-	-	-
		Power factor	-	0.70	0.69	0.80	0.84	0.84
		Efficiency	-	0.76	0.78	0.89	0.89	0.90
		Load	tm/min	15.4	30	60	76	120
		Nominal power	kW	2.9	5.4	11	14	21
		Nominal torque	Nm	7.7	15.3	30	38	62
		Nominal speed	rpm	3470	3515	3550	3540	3540
		Short time duty	min	-	-	-	-	-
		Power factor	-	0.63	0.62	0.77	0.80	0.80
Efficiency	-	0.73	0.75	0.88	0.89	0.91		
External Fan	Type		NM901NR10	NM901NR20	NM901NR30	NM901NR30	NM901NR30	
	Voltage range	3-50Hz	220-290V D 380-500V Y	220-290V D 380-500V Y	220-290V D 380-500V Y	220-290V D 380-500V Y	220-290V D 380-500V Y	
		3-60Hz	220-332V D 380-575V Y	220-332V D 380-575V Y	220-332V D 380-575V Y	220-332V D 380-575V Y	220-332V D 380-575V Y	
	Current	3-50Hz	0.35A D 0.19A Y	0.33A D 0.18A Y	0.45A D 0.24A Y	0.45A D 0.24A Y	0.45A D 0.24A Y	
3-60Hz		0.32A D 0.18A Y	0.31A D 0.18A Y	0.41A D 0.24A Y	0.41A D 0.24A Y	0.41A D 0.24A Y		

3.9 Hoisting motor data, frequency converter motors, 125 Hz

Hoist	Hoisting motor rating	Characteristic	Unit	S3	S5	S7	S8	SA
				MF10ML200	MF11ML200	MF13ZL200	MF13ZJ200	MF13XL200
Standard hoist	300 Starts/h 60 % ED	Rated power	kW	5.6	11.5	22	28	44
		Synchronous speed	rpm	3750	3750	3750	3750	3750
		Max. ESR	rpm	4500	4500	4500	4500	4500
		Brake type	-	NM38730NR2	NM40940NR2	NM40951NR2	NM40980NR2	NM40980NR2
		Brake torque	Nm	42	60	130	200	200
		Pull-out torque	Nm	40	80	200	200	350
		Speed at pull-out torque	rpm	2450	2980	2520	2520	2910
		Speed at 80% pull-out torque	rpm	3190	3250	3410	3410	3400
		Starting torque	Nm	34	64	115	115	220
		Weight	kg	23	37	72	72	99
		Brake inertia	kgm ²	0.00045	0.0007	0.0017	0.0017	0.0017
		Inertia w/o brake	kgm ²	0.0027	0.0075	0.030	0.030	0.043
		Iron losses	W	160	260	260	260	390
		Stator resistance	Ohm	2.0	0.65	0.25	0.25	0.13
		Load	tm/min	31	63	125	156	250
		Nominal power	kW	5.7	11.5	21.9	28.2	42.8
		Nominal torque	Nm	15.3	30	62	76	116
		Nominal speed	rpm	3490	3560	3650	3620	3620
		Short time duty	min	60	30	30	30	30
		Power factor	-	0.80	0.78	0.86	0.88	0.87
Efficiency	-	0.77	0.81	0.89	0.89	0.89		
Special application at lower load ratings	300 starts/h 60 % ED	Load	tm/min	25	50	100	125	200
		Nominal power	kW	4.5	9.4	18.8	21.9	35.5
		Nominal torque	Nm	12.3	24	48	62	96
		Nominal speed	rpm	3540	3590	3670	3650	3650
		Short time duty	min	-	-	-	-	-
		Power factor	-	0.76	0.75	0.84	0.86	0.86
		Efficiency	-	0.77	0.78	0.89	0.89	0.89
		Load	tm/min	20	40	79	100	156
		Nominal power	kW	3.7	7.5	14.6	18.8	28.2
		Nominal torque	Nm	9.8	19.2	38	48	76
		Nominal speed	rpm	3580	3635	3690	3670	3670
		Short time duty	min	-	-	-	-	-
		Power factor	-	0.70	0.69	0.80	0.84	0.84
		Efficiency	-	0.76	0.78	0.89	0.89	0.90
		Load	tm/min	16	31	66	79	125
		Nominal power	kW	3	5.7	11	14.6	21.9
		Nominal torque	Nm	7.7	15.3	30	38	62
		Nominal speed	rpm	3620	3665	3700	3690	3690
		Short time duty	min	-	-	-	-	-
		Power factor	-	0.63	0.62	0.77	0.80	0.80
Efficiency	-	0.73	0.75	0.88	0.89	0.91		
External Fan	Type		NM901NR10	NM901NR20	NM901NR30	NM901NR30	NM901NR30	
	Voltage range	3~ 50Hz	220-290V D 380-500V Y	220-290V Y 380-500V D	220-290V Y 380-500V D	220-290V Y 380-500V D	220-290V Y 380-500V D	
		3~ 60Hz	220-332V D 380-575V Y	220-332V Y 380-575V D	220-332V Y 380-575V D	220-332V Y 380-575V D	220-332V Y 380-575V D	
	Current	3~ 50Hz	0.35A D 0.19A Y	0.33A D 0.18A Y	0.45A D 0.24A Y	0.45A D 0.24A Y	0.45A D 0.24A Y	
3~ 60Hz		0.32A D 0.18A Y	0.31A D 0.18A Y	0.41A D 0.24A Y	0.41A D 0.24A Y	0.41A D 0.24A Y		

3.10 Hoisting motor currents, frequency converter motors, 100 Hz, 120 Hz and 125 Hz

		100Hz		120Hz		125Hz	
Nominal voltage		400 V		460 V		500 V	
Used in voltage range		380...415 V		440...480 V		500 V	
		tm/min	Current (Amperes)	tm/min	Current (Amperes)	tm/min	Current (Amperes)
S3 MF10ML200	Current at 80% of pull-out torque	-	21.2	-	21.5	-	21.5
	Nominal current	25	10.7	30	10.8	31	10.8
		20	9.3	24	9.3	25	9.3
		16	8.3	19.2	8.1	20	8.1
		12.5	7.6	15	7.5	16	7.5
	No-load current	-	6.3	-	5.9	-	5.9
S5 MF11ML200	Current at 80% of pull-out torque	-	42	-	42	-	42
	Nominal current	50	21	60	22	63	22
		40	18	48	19	50	19
		32	15.5	38	17	40	17
		25	14.3	30	15.0	31	15.0
	No-load current	-	11.8	-	11.0	-	11.0
S7 MF13ZL200	Current at 80% of pull-out torque	-	90	-	93	-	93
	Nominal current	100	34	120	36	125	36
		80	28	96	29	100	29
		63	24	76	25	79	25
		50	23	63	24	66	24
	No-load current	-	17	-	16	-	16
S8 MF13ZJ200	Current at 80% of pull-out torque	-	90	-	93	-	93
	Nominal current	125	42	150	44	156	44
		100	34	120	36	125	36
		80	28	96	29	100	29
		63	24	76	25	79	25
	No-load current	-	17	-	16	-	16
SA MF13XL200	Current at 80% of pull-out torque	-	157	-	160	-	160
	Nominal current	200	64	240	65	250	65
		160	57	192	56	200	56
		125	48	150	48	156	48
		100	42	120	41	125	41
	No-load current	-	26	-	23	-	23

4 TRAVELING MOTORS

These motors are driven with fixed voltages and frequencies with the below specified line voltages (=frequency converter supply voltage). Motor nameplate data is the same for all line voltages. Other voltage/frequency versions are not available for these motors.

4.1 Frequency converter traveling motors 3000 rpm (100 Hz), 3600 rpm (120 Hz) and 4800 rpm (80 Hz)

Duty type	Motor code	MF06MA100	MF06MA200		MF06LA100	MF06LA200		MF06LA20P		
	Speed control	frequency converter	frequency converter		frequency converter	frequency converter		frequency converter		
	Frequency converter supply voltage	380-480V	380-480V	440-480V	380-480V	380-480V	440-480V	380-480V	440-480V	
	Motor voltage	400 V	400 V	460 V	400 V	400 V	460 V	400 V	460 V	
	Frequency	80 Hz	100 Hz	120 Hz	80 Hz	100 Hz	120 Hz	100 Hz	120 Hz	
Brake type	compact	compact	compact	compact	compact	compact	compact	compact	compact	
Synchronous speed	rpm	4800	3000	3600	4800	3000	3600	3000	3600	
Brake torque	Nm	2	2	2	2	2	2	2	2	
Starting torque	Nm	3.2	3.0	2.9	5.6	7.2	7.1	7.2	7.1	
Electric braking torque	Nm									
Starting current	A	6.5	4.2	4.3	10.3	8.2	8.5	8.2	8.5	
Maximum torque	Nm	3.2	3.0	2.9	5.6	7.2	7.1	7.2	7.1	
Speed at max. torque	rpm	0	0	0	0	0	0	0	0	
80% of max. torque	Nm	2.6	2.4	2.4	4.5	5.7	5.7	5.7	5.7	
Speed at 80% torque	rpm	3700	2200	2600	3600	2200	2650	2200	2650	
Current at 80% torque	A	3.8	2.1	2.1	6.0	4.8	4.8	4.8	4.8	
Inertia	kgm ²	0.0004	0.0004	0.0004	0.0007	0.0007	0.0007	0.0007	0.0007	
Inertia with flywheel	kgm ²									
Power factor, starting	-	0.74	0.72	0.70	0.75	0.71	0.69	0.71	0.69	
Weight with fan	kg									
Weight	kg	4.9	4.9	4.9	6.8	6.8	6.8	6.8	6.8	
No-load current	A	1.2	1.0	1.0	1.1	1.6	1.6	1.6	1.6	
Iron losses	W									
Stator resistance at 20 °C	Ω	19.5	34	34	12.2	14.7	14.7	14.7	14.7	
S3-20%	Speed	rpm	4550	2760	3380	4500	2780	3330		
	Power	kW	0.45	0.45	0.45	0.9	0.75	0.75		
	Current	A	2.1	1.4	1.4	2.3	2.3	2.3		
	Starting burden	kgm ² /h								
	Power factor	-	0.63	0.68	0.63	0.77	0.67	0.67		
	Efficiency	-	0.66	0.66	0.66	0.72	0.74	0.74		
S3-40%	Speed	rpm	4550	2855	3430	4560	2850	3440	2800	3360
	Power	kW	0.45	0.3	0.37	0.65	0.45	0.55	0.65	0.75
	Current	A	2.1	1.2	1.2	2.1	1.8	1.8	2.1	2.1
	Starting burden	kgm ² /h								
	Power factor	-	0.63	0.57	0.59	0.71	0.52	0.53	0.61	0.61
	Efficiency	-	0.66	0.65	0.65	0.68	0.73	0.74	0.73	0.74
S3-60%	Speed	rpm		2855	3450	4640	2850	3470		
	Power	kW		0.3	0.3	0.45	0.45	0.45		
	Current	A		1.2	1.2	1.8	1.8	1.8		
	Starting burden	kgm ² /h								
	Power factor	-		0.57	0.59	0.60	0.52	0.52		
	Efficiency	-		0.65	0.65	0.64	0.73	0.73		
S3-100%	Speed	rpm								
	Power	kW								
	Current	A								
	Starting burden	kgm ² /h								
	Power factor	-								
	Efficiency	-								

...Frequency converter traveling motors, Continued...

Duty type	Motor code		MF06LB100	MF06LB200		MF07XA100	MF07XB100	MF07XA200		MF07XB200	
	Speed control		frequency converter	frequency converter		frequency converter	frequency converter	frequency converter		frequency converter	
	Frequency converter supply voltage		380-480V	380-480V	440-480V	380-480V	380-480V	380-480V	440-480V	380-480V	440-480V
	Motor voltage		400 V	400 V	460 V	400 V	400 V	400 V	460 V	400 V	460 V
	Frequency		80 Hz	100 Hz	120 Hz	80 Hz	80 Hz	80 Hz	100 Hz	120 Hz	100 Hz
Brake type		DC	DC	DC	DC	DC	DC	DC	DC	DC	DC
Synchronous speed	rpm	4800	3000	3600	4800	4800	3000	3600	3000	3600	
	Brake torque	Nm	4	4	4	16	16	16	16	16	16
	Starting torque	Nm	10.4	10.5	10.4	11.7	16.5	13.5	12.7	23.5	21.6
	Electric braking torque	Nm									
	Starting current	A	16.4	12.9	12.6	23.5	32	19.3	19.4	35	34
	Maximum torque	Nm	10.4	11	10.8	12	17	17.5	16.5	25	23
	Speed at max. torque	rpm	0	1480	1770	2250	2200	2010	2410	1590	1910
	80% of max. torque	Nm	8.3	8.9	8.9	9.6	13	14	13.1	20	18
	Speed at 80% torque	rpm	3350	2350	2820	3770	4050	2620	3140	2470	2970
	Current at 80% torque	A	9.0	6.6	6.6	10.4	14	10	10.6	15	13.5
	Inertia	kgm ²	0.0006	0.0006	0.0006	0.0012	0.0012	0.0012	0.0012	0.0012	0.0012
	Inertia with flywheel	kgm ²									
	Power factor, starting	-	0.84	0.77	0.74	0.77	0.79	0.67	0.63	0.67	0.64
	Weight with fan	kg				13	13	13	13	13	13
	Weight	kg	7.8	7.8	7.8						
No-load current	A	2.0	2.2	2.0	2.6	6.0	2.5	2.3	5.4	4.9	
Iron losses	W										
Stator resistance at 20 °C	Ω	8.8	10.4	10.4	5.6	3.75	6.3	6.3	3.8	3.8	
S3-20%	Speed	rpm	4450	2720	3320	4440	4420	2820	3370	2840	3440
	Power	kW	1.3	1.3	1.3	2.2	3.6	1.8	2.2	2.5	3
	Current	A	3.1	3.3	3.2	5.0	8.8	4.3	4.6	7.2	6.9
	Starting burden	kgm ² /h									
	Power factor	-	0.82	0.77	0.74	0.88	0.79	0.79	0.81	0.68	0.71
	Efficiency	-	0.78	0.73	0.76	0.74	0.74	0.74	0.75	0.74	0.76
S3-40%	Speed	rpm	4500	2770	3370	4520	4460	2850	3430	2860	3460
	Power	kW	1.1	1.1	1.1	1.8	3	1.5	1.8	2.2	2.5
	Current	A	2.9	3.0	2.9	4.3	7.9	3.9	3.9	6.9	6.5
	Starting burden	kgm ² /h									
	Power factor	-	0.78	0.73	0.74	0.84	0.78	0.75	0.76	0.66	0.68
	Efficiency	-	0.78	0.74	0.76	0.75	0.74	0.75	0.76	0.73	0.75
S3-60%	Speed	rpm	4600	2840	3450	4520	4460	2850	3430	2860	3460
	Power	kW	0.75	0.65	0.65	1.8	3	1.5	1.8	2.2	2.5
	Current	A	2.3	2.5	2.4	4.3	7.9	3.9	3.9	6.9	6.5
	Starting burden	kgm ² /h									
	Power factor	-	0.65	0.60	0.62	0.84	0.78	0.75	0.76	0.66	0.68
	Efficiency	-	0.75	0.70	0.71	0.75	0.74	0.75	0.76	0.73	0.75
S3-100%	Speed	rpm				4520		2850	3430	2890	3480
	Power	kW				1.8		1.5	1.8	1.8	2.2
	Current	A				4.3		3.9	3.9	6.4	6.1
	Starting burden	kgm ² /h									
	Power factor	-				0.84		0.75	0.76	0.59	0.63
	Efficiency	-				0.75		0.75	0.76	0.70	0.74

4.2 Two-speed traveling motors 3000/750 rpm (50 Hz) and 3600/900 rpm (60 Hz)

Duty type	Motor code	MF06MA104		MF06MA104		MF06LA104		MF06LA104		
	Speed control	2-speed		2-speed		2-speed		2-speed		
	Voltage	380V - 415V		440V - 480V		380V - 415V		440V - 480V		
	Frequency	50 Hz		60 Hz		50 Hz		60 Hz		
Brake type	DC		DC		DC		DC			
		High	Low	High	Low	High	Low	High	Low	
	Synchronous speed	rpm	3000	750	3600	900	3000	750	3600	900
	Brake torque	Nm	2	2	2	2	2	2	2	2
	Starting torque	Nm	2.2	1.7	2.2	1.8	3.3	2.5	3.3	2.4
	Electric braking torque	Nm	5.6/2.0		5.6/2.0		8/3.5		8/3.5	
	Starting current	A	3.5	1.0	3.9	1.1	5.0	1.4	5.3	1.5
	Maximum torque	Nm	2.2	1.8	2.2	1.8	3.6	2.7	3.5	2.6
	Speed at max. torque	rpm	2150	400	2750	550	1620	380	2220	530
	80% of max. torque	Nm	1.7	1.4	1.7	1.4	2.8	2.1	2.7	2.0
	Speed at 80% torque	rpm	2500	570	3080	740	2100	530	2800	680
	Current at 80% torque	A	1.5	0.8	1.5	0.8	2.3	1.3	2.2	1.3
	Inertia	kgm ²	0.0004	0.0004	0.0004	0.0004	0.0006	0.0006	0.0006	0.0006
	Inertia with flywheel	kgm ²								
	Power factor, starting	-	0.94	0.93	0.91	0.92	0.92	0.93	0.91	0.92
	Weight with fan	kg								
	Weight	kg	5.7	5.7	5.7	5.7	7.8	7.8	7.8	7.8
	No-load current	A	0.9	0.8	0.9	0.8	1.1	1.2	1.1	1.2
	Iron losses	W								
	Stator resistance at 20 °C	Ω	69	280	69	280	50	175	50	175
S3-20%	Speed	rpm	2800	690	3400	810	2760	660	3340	810
	Power	kW	0.3	0.05	0.37	0.07	0.45	0.1	0.55	0.12
	Current	A	1.0	0.8	0.9	0.9	1.3	1.2	1.3	1.2
	Starting burden	kgm ² /h	2		1.4		3		2.1	
	Power factor	-	0.7	0.77	0.74	0.78	0.83	0.67	0.82	0.80
	Efficiency	-	0.67	0.12	0.67	0.12	0.67	0.20	0.67	0.20
S3-40%	Speed	rpm	2800	690	3400	810	2760	660	3340	810
	Power	kW	0.3	0.05	0.37	0.07	0.45	0.1	0.55	0.12
	Current	A	1.0	0.8	0.9	0.9	1.3	1.2	1.3	1.2
	Starting burden	kgm ² /h	1.5		1.0		2.5		1.9	
	Power factor	-	0.7	0.77	0.74	0.78	0.83	0.67	0.82	0.80
	Efficiency	-	0.67	0.12	0.67	0.12	0.67	0.20	0.67	0.20
S3-60%	Speed	rpm								
	Power	kW								
	Current	A								
	Starting burden	kgm ² /h								
	Power factor	-								
	Efficiency	-								
S3-100%	Speed	rpm								
	Power	kW								
	Current	A								
	Starting burden	kgm ² /h								
	Power factor	-								
	Efficiency	-								

...Two speed traveling motors, Continued...

Duty type	Motor code	MF07X-104		MF07X-104		MF07XA104		MF07XA104		MF10M-104		MF10M-104		
	Speed control	2-speed		2-speed		2-speed		2-speed		2-speed		2-speed		
	Voltage	380V - 415V		440V - 480V		380V - 415V		440V - 480V		380V - 415V		440V - 480V		
	Frequency	50 Hz		60 Hz		50 Hz		60 Hz		50 Hz		60 Hz		
	Brake type	DC		DC		DC		DC		DC		DC		
		High	Low	High	Low	High	Low	High	Low	High	Low	High	Low	
Synchronous speed	Synchronous speed	rpm	3000	750	3600	900	3000	750	3600	900	3000	750	3600	900
	Brake torque	Nm	8	8	8	8	8	8	8	8	21	21	21	21
	Starting torque	Nm	5.8	5.2	5.6	4.8	7.5	5.4	6.9	5.0	10	8	10	8
	Electric braking torque	Nm		10/9		10/9		11/9		11/9		33/13		33/13
	Starting current	A	8.0	2.4	8.0	2.3	9.9	3.1	10	3.1	12.8	3.0	13.7	3.3
	Maximum torque	Nm	5.9	5.2	5.7	4.8	7.5	5.4	6.9	5.0	10.3	8	10.3	8
	Speed at max. torque	rpm	1700	0	2040	0	0	0	0	0	1380	0	1650	0
	80% of max. torque	Nm	4.6	4.1	4.5	3.8	6	4.3	5.5	4	8	6.4	8	6.4
	Speed at 80% torque	rpm	2400	590	2880	710	2360	505	2830	605	2380	570	2850	680
	Current at 80% torque	A	3.9	2.3	3.6	2.3	4.9	2.4	4.7	2.4	5.5	1.7	5.6	1.7
	Inertia	kgm ²	0.0012	0.0012	0.0012	0.0012	0.0012	0.0012	0.0012	0.0012	0.0027	0.0027	0.0027	0.0027
	Inertia with flywheel	kgm ²	0.0036	0.0036	0.0036	0.0036	0.0036	0.0036	0.0036	0.0036	0.018	0.018	0.018	0.018
	Power factor, starting	-	0.90	0.80	0.89	0.78	0.89	0.79	0.88	0.76	0.83	0.84	0.79	0.81
	Weight with fan	kg												
	Weight with flywheel	kg	13.5	13.5	13.5	13.5	13.5	13.5	13.5	13.5	26	26	26	26
	No-load current	A	2.2	1.7	1.9	1.7	3.2	2.2	3.0	2.2	1.3	1.2	1.2	1.2
	Iron losses	W												
Stator resistance at 20 °C	Ω	23	75	23	75	19	72	19	72	13.5	69	13.5	69	
S3-20%	Speed	rpm	2720	590	3370	750	2730	590	3310	740	2500	585	3200	750
	Power	kW	0.75	0.18	0.9	0.2	0.9	0.2	1.1	0.25	1.5	0.35	1.8	0.4
	Current	A	2.7	1.9	2.7	1.9	3.5	2.3	3.4	2.3	4.6	1.6	3.8	1.6
	Starting burden	kgm ² /h	7		4.9		7.1		5		10		6.9	
	Power factor	-	0.80	0.67	0.79	0.64	0.74	0.70	0.77	0.63	0.92	0.77	0.91	0.75
	Efficiency	-	0.57	0.24	0.62	0.26	0.59	0.21	0.62	0.25	0.62	0.45	0.68	0.50
S3-40%	Speed	rpm	2720	590	3370	750	2730	590	3310	740	2700	630	3310	780
	Power	kW	0.75	0.18	0.9	0.2	0.9	0.2	1.1	0.25	1.3	0.3	1.5	0.35
	Current	A	2.7	1.9	2.7	1.9	3.5	2.3	3.4	2.3	3.0	1.4	3.0	1.4
	Starting burden	kgm ² /h	6.5		4.5		6.6		4.6		8		5.6	
	Power factor	-	0.80	0.67	0.79	0.64	0.74	0.70	0.77	0.63	0.89	0.70	0.89	0.68
	Efficiency	-	0.57	0.24	0.62	0.26	0.59	0.21	0.62	0.25	0.69	0.47	0.70	0.51
S3-60%	Speed	rpm	2720	590	3370	750				2700	630	3310	780	
	Power	kW	0.75	0.18	0.9	0.2				1.3	0.3	1.5	0.35	
	Current	A	2.7	1.9	2.7	1.9				3.0	1.4	3.0	1.4	
	Starting burden	kgm ² /h	5.8		4					6		4.2		
	Power factor	-	0.80	0.67	0.79	0.64				0.89	0.70	0.89	0.68	
	Efficiency	-	0.57	0.24	0.62	0.26				0.69	0.47	0.70	0.51	
S3-100%	Speed	rpm								2700	630	3310	780	
	Power	kW								1.3	0.3	1.5	0.35	
	Current	A								3.0	1.4	3.0	1.4	
	Starting burden	kgm ² /h								4		2.8		
	Power factor	-								0.89	0.70	0.89	0.68	
	Efficiency	-								0.69	0.47	0.70	0.51	

5 TROLLEY SPEED TABLES

5.1 Trolley traveling speed range, Frequency converter control

Low headroom trolley, Frequency converter control

Frame	Rope Reeving	Duty		Gear type		Wheel diameter [mm]	Motor type	Nr of motors	Speed range [m/min] ¹⁾		
									Min	380V-415V Max	460V-480V Max
NB	02		M5	M6	GEK 106	80	MF06MA200	1	10	20	24
	02		M5	M6	GEK 106	80	MF06MA100	1	16	32	32
	04		M5	M6	GEK 106	80	MF06MA200	1	10	20	24
	04		M5	M6	GEK 106	80	MF06MA100	1	16	32	32
NC	A2		M5	M6	GEK 106	100	MF06MA200	1	10	20	24
	A2		M5	M6	GEK 106	100	MF06MA100	1	16	32	32
	A4		M5	M6	GEK 106	100	MF06MA200	1	10	20	24
	A4		M5	M6	GEK 106	100	MF06MA100	1	16	32	32
	02	M4	M5	M6	GEK 106	100	MF06LA200	1	10	20	24
	02	M4	M5	M6	GEK 106	100	MF06LA100	1	16	32	32
	04		M5	M6	GEK 106	100	MF06LA200	1	10	20	24
	04		M5	M6	GEK 106	100	MF06LA100	1	16	32	32
	04	M4			GEK 106	125	MF06LA200	1	10	20	24
	04	M4			GEK 106	125	MF06LA100	1	16	32	32
ND	02	M4	M5	M6	GEK 106	125	MF06MA200	2	10	20	24
	02	M4	M5	M6	GEK 106	125	MF06LA100	2	16	32	32
	04		M5	M6	GEK 106	125	MF06LA200	2	10	20	24
	04		M5	M6	GEK 106	125	MF06LA100	2	16	32	32
	04	M4			GEK 106	150	MF06LA200	2	12.5	25	30
	04	M4			GEK 106	150	MF06LA100	2	20	40	40

¹⁾ The maximum speed depends on the line voltage. With higher line voltage greater speeds can be achieved.

The table is calculated with maximum loads for the hoists. With derated loads it may be possible to use smaller frequency converters. In these cases the frequency converter selection must be verified with KC Drive or Markman.

Normal headroom trolley, Frequency converter control

Frame	Rope Reeving	Duty		Gear type		Wheel diameter [mm]	Motor type	Nr of motors	Speed range [m/min] ¹⁾		
									Min	380V-415V Max	460V-480V Max
NB	02		M5	M6	GEK 106	100	MF06LA200	1	10	20	24
	02		M5	M6	GEK 106	100	MF06LA100	1	16	32	32
	04		M5	M6	GEK 106	100	MF06LA200	1	10	20	24
	04		M5	M6	GEK 106	100	MF06LA100	1	16	32	32
NC	02		M5	M6	GEK 106	100	MF06LA200	1	10	20	24
	02		M5	M6	GEK 106	100	MF06LA100	1	16	32	32
	04		M5	M6	GEK 106	100	MF06LA200	1	10	20	24
	04		M5	M6	GEK 106	100	MF06LA100	1	16	32	32
ND	02/22		M5	M6	GEK 106	100	MF06MA200	2	10	20	24
	02/22		M5	M6	GEK 106	100	MF06LA100	2	16	32	32
	04/24		M5	M6	GEK 106	100	MF06LA200	2	10	20	24
	04/24		M5	M6	GEK 106	100	MF06LA100	2	16	32	32
	06/26		M5	M6	GEK 106	125	MF06MA200	4	10	20	24
	06/26		M5	M6	GEK 106	125	MF06LA100	4	16	32	32
	08/28		M5	M6	GEK 106	125	MF06MA200	4	10	20	24
	08/28		M5	M6	GEK 106	125	MF06LA100	4	16	32	32
NE	02/22	M4	M5	M6	GEK 106	125	MF06LA200	2	10	20	25
	02/22	M4	M5	M6	GEK 106	125	MF06LA100	2	16	32	32
	04	M4	M5	M6	GES 320	180	MF06LA200	3	10	20	24
	04	M4	M5	M6	GES 320	180	MF06LA100	4	16	32	32
	24	M4	M5	M6	GEK 106	125	MF06LA200	3	10	20	24
	24	M4	M5	M6	GEK 106	125	MF06LA100	4	16	32	32
	06/26	M4	M5	M6	GES 320	180	MF06LA200	3	10	20	24
	06/26	M4	M5	M6	GES 320	180	MF06LA100	4	16	32	32
28	M4	M5		GES 320	180	MF06LA200	4	10	20	24	

¹⁾ The maximum speed depends on the line voltage. With higher line voltage greater speeds can be achieved.

The table is calculated with maximum loads for the hoists. With derated loads it may be possible to use smaller frequency converter. In these cases the frequency converter selection must be verified with KC Drive or Markman.

Double girder trolley, Frequency converter control

Frame	Rope reeving	Load	End truck	Gear	Motor	Nr of motors	Speed Range [m/min] ¹⁾		
							Min	380V-415V Max	460V-480V Max
NB	02	1.6t M5	QNC 09	GES 342	MF06MA200	1	10	20	24
	02	1.6t M5	QNC 09	GES 342	MF06MA100	1	16	32	32
	04	3.2t M5	QNC 09	GES 342	MF06MA200	1	10	20	24
	04	3.2t M5	QNC 09	GES 342	MF06MA100	1	16	32	32
NC	02	3.2t M4	QNC 09	GES 342	MF06LA200	1	10	20	24
	02	3.2t M4	QNC 09	GES 342	MF06LA100	1	16	32	32
	04	5t M5	QNC 09	GES 342	MF06LA200	1	10	20	24
	04	5t M5	QNC 09	GES 342	MF06LA100	1	16	32	32
	04	6.3t M4	QNC 09	GES 342	MF06LA200	1	10	20	24
	04	6.3t M4	QNC 09	GES 342	MF06LA100	1	16	32	32
ND	02/22	6.3t M4	QNC 11	GES 342	MF06MA200	2	10	20	24
	02/22	6.3t M4	QNC 11	GES 342	MF06LA100	2	20	40	40
	04/24	10t M5	QNC 11	GES 342	MF06MA200	2	10	20	24
	04/24	10t M5	QNC 11	GES 342	MF06LA100	2	20	40	40
	04	12.5t M4	QNC 11	GES 342	MF06LA200	2	10	20	24
	04	12.5t M4	QNC 11	GES 342	MF06LA100	2	20	40	40
	06/26	15t M5	QNC 14	GES 342	MF06LA20P	2	15	32	32
	08/28	20t M4	QNC 14	GES 342	MF06LA20P	2	10	32	32
NE	02/22	10t M4	QNC 14	GES 342	MF06LA200	2	16	32	32
	04/24	20t M4	QNC 14	GES 342	MF06LA20P	2	10	32	32
	06/26	30t M4	QNC 20	GES 490	MF06LA20P	2	10	20	24
	06/26	30t M4	QNC 20	GES 490	MF06LB100	2	10	32	32
	08/28	40t M4	QNC 20	GES 490	MF06LB200	2	10	20	24
	08/28	40t M4	QNC 20	GES 490	MF06LB100	2	10	32	32
NF	22	20t M4	QNC 20	GES 490	MF06LA200	2	10	20	24
	22	20t M4	QNC 20	GES 490	MF06LB100	2	10	32	32
	24	40t M4	QNC 20	GES 490	MF06LB200	2	10	20	24
	24	40t M4	QNC 20	GES 490	MF06LB100	2	10	32	32
	26	60t M4	QNC 25	GES 590	MF07XA200	2	10	25	25
	26	60t M4	QNC 25	GES 572	MF07XA200	2	10	32	32
	28	80t M4	QNC 25B	GES 590	MF07XA200	2	10	25	25
	28	80t M4	QNC 25B	GES 572	MF07XB200	2	10	32	32

¹⁾ The maximum speed depends on the line voltage. With higher line voltage greater speeds can be achieved.

The table is calculated with maximum loads for the hoists. With derated loads it may be possible to use smaller frequency converter. In these cases the frequency converter selection must be verified with KC Drive or Markman.

5.2 Trolley traveling speeds, Contactor control

Low headroom trolley

Frame	Reeving	Duty		Gear type	Wheel diameter	Motor type	Nr of motors	50 Hz		60 Hz		
								High	Low	High	Low	
NB	02		M5	M6	GEK 106PT1B0	80	MF06MA104	1	20	5	24	6
	04		M5	M6	GEK 106PT1B0	80	MF06MA104	1	20	5	24	6
NC	A2		M5	M6	GEK 106PT1B0	100	MF06MA104	1	20	5	24	6
	A4		M5	M6	GEK 106PT1B0	100	MF06MA104	1	20	5	24	6
	02	M4	M5	M6	GEK 106PT1B0	100	MF06MA104	1	20	5	24	6
	04	M4	M5	M6	GEK 106PT1B0	100	MF06MA104	1	20	5	24	6
ND	02	M4	M5	M6	GEK 106PT1B0	125	MF06MA104	2	20	5	24	6
	04		M5	M6	GEK 106PT1B0	125	MF06MA104	2	20	5	24	6
	04	M4			GEK 106PT1B0	150	MF06LA104	2	24	6	29	7

Normal headroom trolley

Frame	Reeving	Duty		Gear type	Wheel diameter	Motor type	Nr of motors	50 Hz		60 Hz		
								High	Low	High	Low	
NB	02		M5	M6	GEK 106PT1B0	100	MF06LA104	1	20	5	24	6
	04		M5	M6	GEK 106PT1B0	100	MF06LA104	1	20	5	24	6
NC	02		M5	M6	GEK 106PT1B0	100	MF06LA104	1	20	5	24	6
	04		M5	M6	GEK 106PT1B0	100	MF06LA104	1	20	5	24	6
ND	02/22		M5	M6	GEK 106PT1B0	100	MF06MA104	2	20	5	24	6
	04/24		M5	M6	GEK 106PT1B0	100	MF06MA104	2	20	5	24	6
	06/26		M5		GEK 106PT1B0	125	MF06MA104	4	20	5	24	6
	08/28	M4			GEK 106PT1B0	125	MF06MA104	4	20	5	24	6
NE	02/22	M4	M5	M6	GEK 106PT1B0	125	MF06LA104	2	20	5	24	6
	04	M4	M5	M6	GES 320PT3B0	180	MF06LA104	3	20	5	24	6
	24	M4	M5	M6	GEK 106PT1B0	125	MF06LA104	3	20	5	24	6
	06/26	M4	M5	M6	GES 320PT3B0	180	MF06LA104	3	20	5	24	6
	28		M5	M6	GES 320PT3B0	180	MF06LA104	4	20	5	24	6

Double girder trolley

Frame	Reeving	Load	End truck		Gear		Motor	Nr of motors	Speed 50Hz		Speed 60Hz		Note!
									High	Low	High	Low	
NB	02	1.6t M5	QNC	9	GES	342	MF06MA104	1	20	5	24	6	
	04	3.2t M5	QNC	9	GES	342	MF06MA104	1	20	5	24	6	
NC	02	3.2t M4	QNC	9	GES	342	MF06MA104	1	20	5	24	6	
	04	6.3t M4	QNC	9	GES	342	MF06LA104	1	20	5	24	6	
ND	02/22	6.3t M4	QNC	11	GES	342	MF06MA104	2	20	5	24	6	
	04/24	12.5t M4	QNC	11	GES	342	MF06LA104	2	20	5	24	6	
	06/26	15t M5	QNC	20	GES	490	MF06LA104	2	20	5	24	6	*
	08/28	20t M4	QNC	20	GES	490	MF06LA104	2	20	5	24	6	*
NE	02/22	10t M4	QNC	20	GES	490	MF06LA104	2	20	5	24	6	*
	04/24	20t M4	QNC	20	GES	490	MF06LA104	2	20	5	24	6	*
	06/26	30t M4	QNC	25	GES	5B5	MF07X-104	2	20	5	24	6	*
	08/28	40t M4	QNC	25	GES	5B5	MF07X-104	2	20	5	24	6	*
NF	22	20t M4	QNC	20	GES	490	MF06LA104	2	20	5	24	6	
	24	40t M4	QNC	25	GES	5B5	MF07X-104	2	20	5	24	6	*
	26	60t M4	QNC	25	GES	5B5	MF10M-104	2	20	5	24	6	
	28	80t M4	QNC	25B	GES	5B5	MF10M-104	2	20	5	24	6	

*) Note: Trolley higher than with frequency converter traveling, consult factory for further information.

6 SURFACE TREATMENT

6.1 Standard painting system

Product group	Wet painting		Alternative: Powder coating	
	Load carrying steel parts	Outfitting steel parts	Load carrying steel parts	Outfitting steel parts
Parts and components Etc.	End plate Support beam Pulley support Hook forging Hook side plate Trolley	Cover	End plate Support beam Pulley support Hook forging Hook side plate Trolley	Cover
Corrosivity Category	C3, durability Low	C3, durability Low	C3, durability Low	C3, durability Low
Standard/ Painting system	SFS-EN ISO 12944-5 EP120/2-FeSa2½	SFS-EN ISO 12944-5 EP120/2-FeSa2½	SFS-EN ISO 12944-5 PE 80/1	SFS-EN ISO 12944-5 PE 80/1
Steel work	05 (SFS 8145)	05 (SFS 8145)	05 (SFS 8145)	05 (SFS 8145)
Preliminary treatment	Wash, removal of grease Shot blasting Sa2½	Wash, removal of grease Zinc- or ironphosphate	Wash, removal of grease Zinc- or ironphosphate	Wash, removal of grease Zinc- or ironphosphate
Priming paint	Epoxy priming paint 1x60 µm	Epoxy priming paint 1x60 µm		
Finishing paint	Epoxy finishing paint 1x60 µm	Epoxy finishing paint 1x60 µm	Epoxy polyester powder coating 1x80 µm	Epoxy polyester powder coating 1x80 µm
Total paint thickness	120 µm	120 µm	80 µm	80 µm

6.2 Color codes

Part	Color code
Hoisting unit	
Hoist frame	RAL 7021
Frame cover	RAL 9006
Hoist motor (frame)	Aluminum
Hoist motor (fan cover)	RAL 7021
Hoist gear (frame)	RAL 7021
Junction box	
Plastic	RAL 7016
Steel	RAL 7021
Rope reeving	
Hook forging	RAL 7021
Cross bar	RAL 7021 / Zinced
Hook sheave cover plate	RAL 1021
Locking plate	RAL 7021
Sheave	RAL 7021
Sheave support	RAL 7021
Rope guide	RAL 7021
Electrical cubicle	
Cubicle bottom	RAL 7021
Cubicle cover (QA/QB-L/N)	RAL 9006
Cubicle cover (others)	RAL 9006
Cubicle support (Low headroom)	RAL 7021
Back plate (Low headroom)	RAL 7021
Counterweight	RAL 9006
Trolley	
All Trolley types	RAL 7021
Travelling machinery	
Travel motor (frame)	Anodised (black)
Travel gear (frame)	RAL 7021
Travel wheel	RAL 7021
Color	
RAL 1021	Cadmium yellow
RAL 7016	Dark grey
RAL 7021	Black grey
RAL 9006	White aluminium
DZ 2369	Green peppermint

7 WIRE ROPE DATA

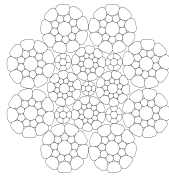

Cross section
Rope type: A

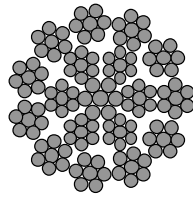

Cross section
Rope type: B

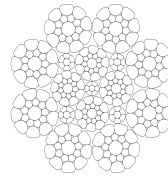

Cross section
Rope type: D and Dr

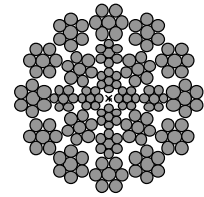

Cross section
Rope type: F and Y

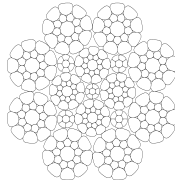

Cross section
Rope type: G and Gr

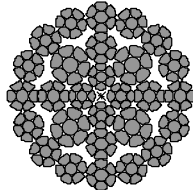

Cross section
Rope type: J, Z and M

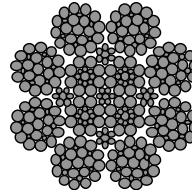

Cross section
Rope type: K and Kr

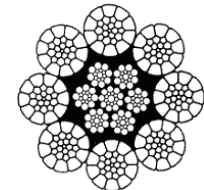

Cross section
Rope type: C, E, Er, H, Hr, L, Lr

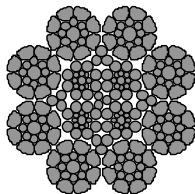

Cross section
Rope type: N

Rope Code	Nominal Diameter [mm]	Minimum Breaking Load [kN]	Construction of the rope	Minimum Rope Grade [N/mm ²]	Core	Compacted Outer Strands	Wire Material	Weight [kg/m]	Lay-Type
N	6.2	36.4	8 x 17	2160	PWRC	Yes	Galvanized steel	0.17	LHO-SD
A	6.4	36.4	8 x 19	2160	PWRC(K)	Yes	Galvanized steel	0.2	LHO-SD
B	6.7	36.7	17 x 7	2160	WC	No	Galvanized steel	0.18	LHO-RR
D	8	65.6	8 x 19	2160	PWRC(K)	Yes	Galvanized steel	0.33	LHO-SD
Dr	8	65.6	8 x 19	2160	PWRC(K)	Yes	Galvanized steel	0.33	RHO-SD
F	8	56.5	24 x 7	2160	WC	No	Galvanized steel	0.27	LHO-RR
Y	8.5	63.5	24 x 7	2160	WC	No	Galvanized steel	0.32	LHO-RR
G	11	127.2	8 x 19	2160	PWRC(K)	Yes	Galvanized steel	0.62	LHO-SD
Gr	11	127.2	8 x 19	2160	PWRC(K)	Yes	Galvanized steel	0.62	RHO-SD
J	11	115.0	28 x 7	2160	WSC	Yes	Galvanized steel	0.56	LHO-RR
Z	11.5	125.0	28 x 7	2160	WSC	Yes	Galvanized steel	0.61	LHO-RR
K	15	214.0	8 x 25	2160	IWRC	No	Galvanized steel	1.03	LHO-SD
Kr	15	214.0	8 x 25	2160	IWRC	No	Galvanized steel	1.03	RHO-SD
M	15	214.0	28 x 7	2160	WSC	Yes	Galvanized steel	1.03	LHO-RR
C	6.5	36.7	8 x 19	1960	EPIWRC	Yes	Galvanized steel	0.2	LHO-HD
E	8	65.6	8 x 19	2160	EPIWRC	Yes	Galvanized steel	0.33	LHO-HD
Er	8	65.6	8 x 19	2160	EPIWRC	Yes	Galvanized steel	0.33	RHO-HD
H	11	128.0	8 x 19	2160	EPIWRC	Yes	Galvanized steel	0.63	LHO-HD
Hr	11	128.0	8 x 19	2160	EPIWRC	Yes	Galvanized steel	0.63	RHO-HD
L	15	214.0	8 x 26	2160	EPIWRC	Yes	Galvanized steel	1.14	LHO-HD
Lr	15	214.0	8 x 26	2160	EPIWRC	Yes	Galvanized steel	1.14	RHO-HD

Abbreviation	Explanation
LHO	Left hand ordinary lay
RHO	Right hand ordinary lay
SD	Rope for Standard Duty Use
HD	Rope for Heavy Duty Use
RR	Rotation Resistant Rope

Abbreviation	Explanation
PWRC	Parallel wire rope centre
PWRC(K)	PWRC with compacted strands
WC	Steel core
WSC	Wire strand core
IWRC	Independent wire rope core
EPIWRC	IWRC covered with a polymer

Suitable alternate ropes: Please see the document 140665.

Notice 1: The shown Minimum Breaking Loads are the minimum allowed and may vary in the delivered ropes.

Notice 2: The shown rope Construction is the nominal and may vary in the delivered ropes.

8 MATERIALS

FIGURE	PART	Fabrication Method						Material									Description	Standard	Standard finishing					
		1	2	3	4	5	6	1	2	3	4	5	6	7	8	9			1	2	3	4		
		1	2	3	4	5	6	1	2	3	4	5	6	7	8	9			1	2	3	4		
A/B HOIST FRAME																								
A4	Drum						•	•											S355	EN10025				
B6	Drum Cover																		POM					
B3	Drum seal ring																		POM					
	Sealing																		PES					
A7	Rope guide	•						•					•						EN-GJS-500-7	EN1563	•			
B4	Frame rods							•	•										S355	EN10025		•		
A1	Frame ends, A,B,C							•											S355MC	EN10149	•	•		
	Frame ends, D,E							•	•										S355	EN10025	•			
	Frame protection cover																		DC01	EN10130	•			
B2	Bearing part, A,B,C																		POM					
B1	Slide Part																		PE-UHMW					
A3	Junction box																		PBT-PC					
	Junction box seal																		PUR					
	Cable duct																		PA					
	Cable duct clamp																		PA					
C HOOK BLOCK																								
	Hook forging																		34CrMo4	EN10083	•			
C1	Hook forging																		34CrNiMo6	EN10083	•			
C2	Cross bar, A,B,C, reeving 04																		S355MC	EN10149	•			
C2	Cross bar																		S355	EN10025	•			
C3	Hook block side plates																		S355	EN10025	•			
C4	Sheave cover																		DC03	EN10130	•			
C ROPE SHEAVE BLOCK																								
C4	Rope sheaves	•																	EN-GJS-700-3	EN1563	•			
C5	Rope sheave shafts																		S355	EN10025	•	•		
C6	Suspension beam																		S355	EN10025	•			
D ROPE ANCHORAGE																								
D1	Rope clamps																		S355	EN10025			•	
D2	Wedge housing	•																	EN-GJS-500-7	EN1563	•			
D3	Wedge	•																	EN-GJS-500-7	EN1563				
D4	Wedge housing shaft																		S355	EN10025			•	
D4	Load pin																		17-4PH	EN 1.4542				
D OVERLOAD DEVICE																								
D5	Frame																		S355	EN10025	•	•		
D6	Lever																		S355	EN10025			•	
D7	Bearing																		S355	EN10025			•	
D8	Fixing plate, D,E																		DC01	EN10130			•	
D9	Limit switch mechanical																		PC, PVC					
D10	Limit switch back up																		PA, POM					
D9	Strain gauge, 3.2kN																		Aluminium					
D9	Strain gauge, 6.3kN, 12.5kN																		S600	EN10025				
	Strain gauge wires																		PVC					
A HOISTING GEARBOX																								
A2	Gearbox housing, A,B	•																	EN AC-AISI7Mg	EN1706	•			
	Gearbox housing, C,D,E	•																	EN-GJS-500-7	EN1563	•			
	Gear wheels																		20NiCrMo2-2	EN10084				
	Shafts inside gearbox																		20NiCrMo2-2	EN10084				
	O-ring																		NBR					
	Coupling																		S355	EN10025				
		1	2	3	4	5	6	1	2	3	4	5	6	7	8	9	Description	Standard	1	2	3	4		

G	HOISTING MOTORS														
G1	Fan cover									•	PP				
G2	Motor fan									•	PA				
G3	Motor frame		•		•					•	EN AW-AlMgSi	EN573			
G6	Friction plate					•					S355	EN10025			
G4	Rotor shaft					•		•			42CrMo4	EN10083			
	Wires									•	Silicon rubber, Fibreglass braid				
G5	Mounting flange	•				•				•	EN AC-AISI10Mg(a)	EN1706			
	Mounting flange, motor MF13	•				•			•		EN-GJL-200	EN1561	•		
E	TRAVELLING GEARBOX														
E10	Gearbox housing	•								•	EN AC-AISI10Mg(a)	EN1706	•		
	Gear wheels										20NiCrMo2-2	EN10084			
	Gearbox shafts										20NiCrMo2-2	EN10084			
E	TRAVELLING MOTOR														
E2	Motor frame		•		•					•	EN AW-AlMgSi	EN573			•
E6	Rotor shaft									•	42CrMo4	EN10083			
E8	Plug cover									•	PPE-PS				
E9	Terminal box									•	PPE-PS				
E7	Motor cover									•	PPE-PS				
E4	Brake wheel					•					DC01	EN10130	•		
E3	Friction disc									•	EN AW-AlMg3	EN573			
E5	Aluminium ring									•	EN AW-AlMgSi	EN573			
	Wires									•	Silicon rubber, Fibreglass braid				
E1	Mounting flange	•								•	EN AW-AISI10Mg	EN1706			
	POWER SUPPLY														
	Cable, plastic									•	PVC				
	Cable, rubber									•	EPDM				
	Cable gland									•	PA				
	Cable gland sealing									•	Neoprene				
	Cable ties, black									•	PA				
	Cable ties, green									•	PP				
	Plug housing									•	PBT-PC				
	Sealing for plug cover									•	EPDM				
	C-Rails									•	S235	EN10025	•		
	PENDANT														
	Cover									•	ABS+PC				
	Micro switch									•	PA				
	Buttons									•	ABS, NBR				
A	ELECTRICAL PANEL														
	CID unit									•	PC				
	Inverter cover									•	PC				
	Control Pro									•	PC				
	ESD142									•	PA				
	Cable gland / Gasket									•	PA				
	Cable gland gasket									•	Neoprene				
	Contactors									•	Thermoplastic				
	Terminal strip									•	PA				
	Wrapped wire									•	PVC V2				
A5	Enclosure		•							•	DC01	EN10130	•		
	Enclosure sealing									•	EPDM				
	LOW HEADROOM TROLLEY														
	Frame beams									•	S355	EN10025	•	•	
	Frame plates			•		•		•			S355	EN10025	•		
	Travel wheel shafts									•	S355	EN10025	•	•	
	Travel wheels	•							•		EN-GJS-700-3	EN1563	•		
	Counter weight				•					•	S235	EN10025	•		
	Grease, Plug cover, A,B,C									•	PA				
	Tube end									•	PA				
	Buffer									•	NR				

	1	2	3	4	5	6	1	2	3	4	5	6	7	8	9	Description	Standard	1	2	3	4
NORMAL HEADROOM TROLLEY																					
Trolley plates					•	•	•									S355	EN10025	•			
Trolley suspension frame					•	•	•									S355	EN10025	•			
Trolley suspension shaft, b<420					•	•	•									S355	EN10025		•		
Trolley suspension shaft, b>420					•	•			•							42CrMo4	EN10083		•		
Travel wheels	•									•						EN-GJS-700-3	EN1563	•			
Travel wheel shafts					•	•										S355	EN10025				
Buffer															•	NR					
DOUBLE GIRDER TROLLEY																					
Trolley wheels	•									•						EN-GJS-700-2	EN1563	•			
Trolley wheel shafts						•	•									S355	EN10025				
Trolley wheel supports	•									•						EN-GJS-500-7	EN1563	•			
Trolley end carriages						•	•									S355	EN10025	•			
Intermediate beam						•	•									S355	EN10025	•			
Buffer															•	NR					
LIMIT SWITCHES																					
2-step travelling limit switch	PBT-PC + GF 30 FR, Aluminium rods																				
Magnetic limit switch	AISI12, painted, lacquered																				
Photo-electric limit switch	ABS, PMMA, PVC, Aluminium, Glass																				
Ultrasonic limit switch	PBT, Nickel-plated Brass, fibre reinforced PUR-EP																				
Hoisting limit switch	PA, AISI 303, POM Delrin 500, PC Lexan																				
Mechanical micro switch	PA, Delrin 500, NBR, Aluminium																				

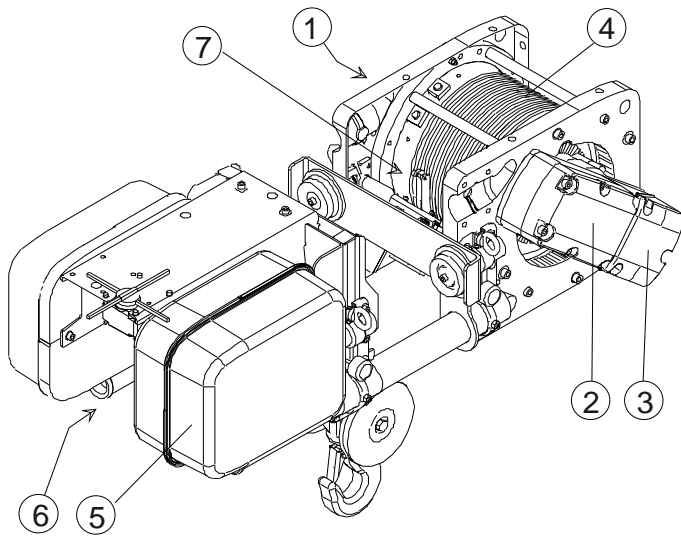

Figure A

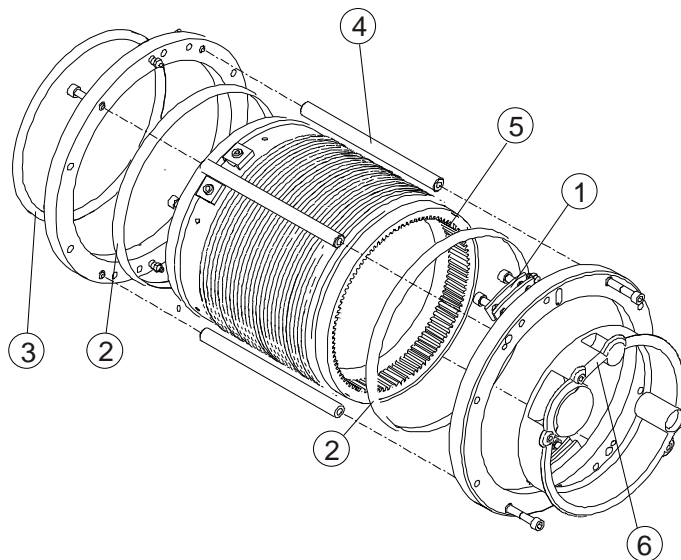

Figure B

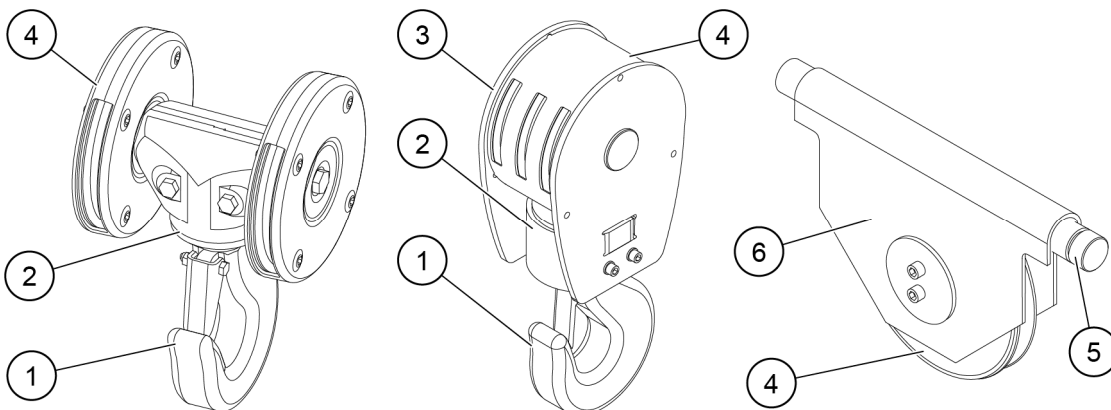

Figure C

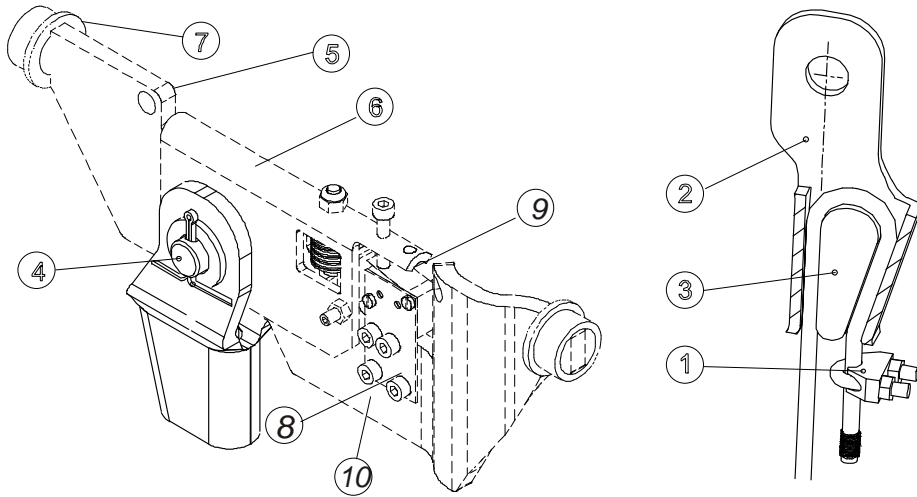

Figure D

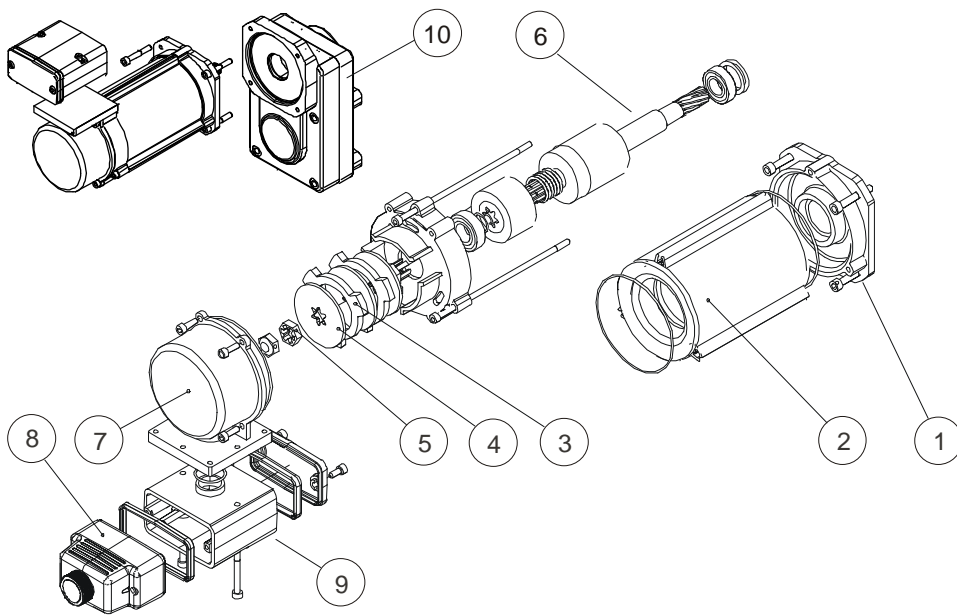

Figure E

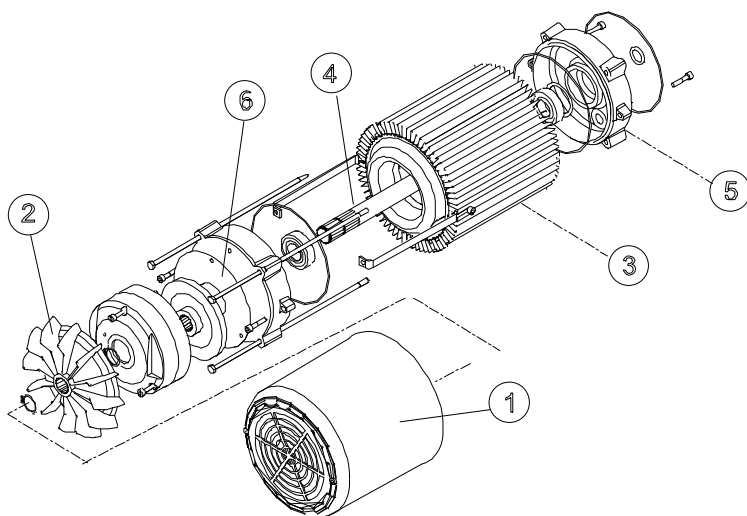

Figure F